

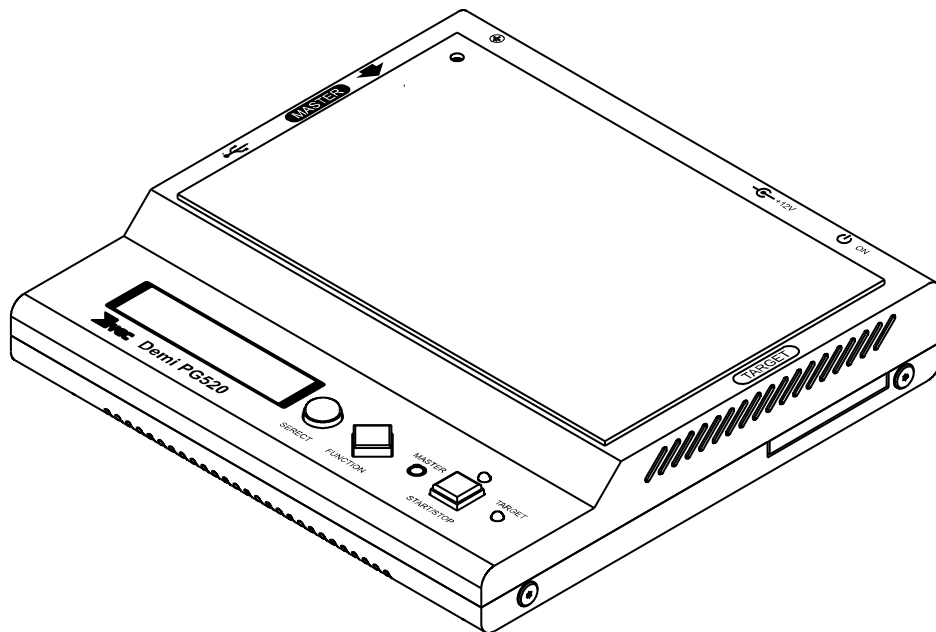

Demi PG520



Operation Manual

Thank you very much for your purchase.
To take full advantage of the performance of this product,
please read this document for proper use.

Introduction

Thank you very much for your purchase.

In this manual, the following markings are used for Demi PG520 (hereinafter referred to as the “this product”) for your continued safety, and in order to prevent the harms to you or other persons, or property damages beforehand.



This mark means the contents that might cause bodily harm or inflict damage to objects in case of mishandling errors without regard to this display.



In case of the following cases, turn off the power immediately, unplug the power plug from an electric socket, and contact us.

- In case of anomalies such as abnormal odors, extraordinary noises or smoking
- The case where this product gets wet



Do not disassemble or modify this product.

It can cause accidents such as fires, electrical shocks / failures / damages.



To install or to remove this product, make sure to confirm the method described in this manual.

In case of operational errors, it may cause fires, electric shock / operational errors / damages.



When installing this product, confirm how to connect and pay attention to the following points based on this manual.

- Use the connection cables and AC codes attached to this product. Use the USB attached to the connecting device. When using other cables or codes, it may cause failures or operational errors.
- When using wrong connectors or cables to connect, it may cause smoking or fires from this product, computers, cables or hard disk.



We cannot guarantee if the data and so on are lost while using this product.

The hard disk is a consumption article. Please back up the hard disk periodically just in case.



Do not use this product under the following conditions.

It may cause this product to malfunction.

- The place where the shock or vibration will occur
- The place where it will be subjected to direct sunlight
- The place where it will be subjected to high or low temperature
- The humid or dusty place
- The place where the magnetism and electricity will be generated (Magnets, speakers, radios, wireless applications, displays etc.)
- The wet location (bathroom, kitchen etc.)
- The place with a lot of static electricity, or the place where it will be susceptible to the static electricity
- Do not use under the condition of the obstructed exhaust fan, or under the
- condition that the exhaust fan might be obstructed



This product is a precision apparatus. Pay attention to the following points.

It may cause this product to malfunction.

- Do not give a drop or a shock.
- Do not put the liquid such as water on this product.
- Do not put heavy objects on this product.



Do not power off or reset while access lamps are lighting.

It can cause failures or loss of data.



Do not touch the substrate of this product.

The substrate in this product has sharp portions. When touched by mistake, it may cause injury. In addition, when touched the substrate, due to static electricity, it can cause failures in this product, destruction or corruption of internal data.



Do not agitate cables in operation.

It can cause destruction or corruption of internal data due to loose connection.

■ Limited Warranty

YEC Co., Ltd. warrants to the original purchaser that this product (Main unit and accessories) shall be free from defects in material and workmanship for a period of one (1) year from the date of purchase (the "Warranty Period"). If this product is determined to be defective during the Warranty Period, YEC Co., Ltd. agrees to either repair or replace, at its option, the YEC product.

Please contact our agency to receive instructions to obtain repair/replacement services.

THIS WARRANTY SHALL NOT APPLY IF THIS PRODUCT; (a) IS DAMAGED BY ACTS OF GOD, MISUSE, ABUSE, NEGLIGENCE, ACCIDENT, WEAR AND TEAR, UNREASONABLE USE, OR BY OTHER CAUSES UNRELATED TO DEFECTIVE MATERIALS OR WORKMANSHIP; (b) HAS HAD THE PRODUCT ALTERED OR DEFACED; OR (c) DAMAGES IN SHIPMENT, OR FAILURES WHICH ARE CAUSED BY PRODUCTS NOT SUPPLIED BY THE WARRANTOR SUCH AS HARD DRIVE.

THE INABILITY OF THIS PRODUCT TO INTERFACE ANY SPECIFIC COMPUTER OR HARD DRIVE IS NOT A MANUFACTURING DEFECT AND IS OUTSIDE OF THE SCOPE OF THIS LIMITED WARRANTY. IN NO EVENT SHALL THE WARRANTOR BE LIABLE BY REASON OF SUCH INCOMPATIBILITY.

PROOF OF PURCHASE IN THE FORM OF A BILL OF SALE OR RECEIPTED INVOICE WHICH IS EVIDENCE THAT THE UNIT IS WITHIN THE WARRANTY PERIOD MUST BE PRESENTED TO OBTAIN WARRANTY SERVICE.

After the expiration of one (1) year from the date of purchase, repairs shall be charged.

■ Disclaimers

While we will take all possible measures for the contents of this manual, please contact us if you have any questions. Notwithstanding the provision of the preceding paragraph, we assume no responsibility for the matters below.

- (1) Any direct or indirect effects and loss of profits raised by this product
- (2) Time and money spent on this product
- (3) Failures/ damages, or troubles/defects etc. caused by modification regardless of our responsibility.
- (4) Loss or damage of the data generated by this product
- (5) Consequences from the use of this product, direct equipment anomalies and other errors

■ Notes

May not be reproduced without the consent of some or all of the contents of our manual of this product and this product. This product may be subjected to change without notice for future improvement.

If you have any doubt about the contents of this document, please contact us.

■ Trademarks

- DOS®, Windows®, Windows NT®, and Windows 95/98/2000®, Windows ME®, Windows XP®, are the registered trademarks of the Microsoft Corporation.
- All other brand and product names are trademarks of their respective owners.

■ Copyrights

If you want to replicate the data of HDD, including copyrighted material with the use of this product, it must be used properly to comply with copyright law.

THE WARRANTOR SHALL NOT BE LIABLE FOR ANY RESULT THAT OCCURS IF IT IS NOT PROPERLY USED IN COMPLIANCE WITH COPYRIGHT LAW.

■ Disposal

Dispose of this product according to the regulation of your local government.

In addition, contact your local government for details of the regulation.

■ Notes on export

Notes on export

Export of this product (including carrying it as personal baggage) may require a permit from the Ministry of Economy, Trade and Industry under an export control law. Export without necessary permit is punishable under the said law. Customer shall inquire of YEC CO., Ltd. sales office whether a permit is required for export or not.

■ Notes on operation

When you operating the product for reading or writing or erasure of the ID or a password or data, permission may be necessary based on law. When you operate without the necessary permits, you will be punished by the law.

■ Repair period

Holding period of performance parts for repair is five (5) years after the discontinuation of manufacturing. However, it may be extended by the holding status of performance parts for repair.

This product is the "Class A information technology equipment". Since the home use may cause interference. In this case, the user may have to take appropriate measures.

VCCI-A

<INDEX>

1	Demi PG520	1
2	Contents of Product	1
3	Name of Parts	2
3.1	TOP SIDE	2
3.2	BACK SIDE	3
3.3	LEFT SIDE	3
3.4	RIGHT SIDE	3
4	Operating Procedures	4
5	Functions	6
5.1	DUPLICATE (DUPLICATE)	6
5.2	CAPACITY SETTING (CLIP).....	6
5.3	DATA ERASING (ERASE).....	7
5.4	SIMPLE DIAGNOSIS (TEST)	7
5.5	HDD INFORMATION DISPLAY (INFORMATION).....	7
5.6	OPERATION SETTING (CONFIG)	8
5.6.1	Parameter Setting	9
5.7	LED LIGHTING	13
5.8	LCD DISPLAY	14
5.8.1	Item selection screen	14
5.8.2	Item execution screen.....	14
5.8.3	Item execution end screen	15
5.8.4	Function selection screen.....	15
5.8.5	Port selection screen.....	16
5.8.6	HDD information display screen	16
5.8.7	Error information display screen.....	22
6	Glossary	24
7	Product Specification	26

1 Demi PG520

This product is available for HDD or SSD copying/comparing, Data erasing, Simple diagnosis supporting the SATA interface.

- SATA 3Gbps supported
This product supports the fast transfer by about 300MB/s (Theoretical value).
- High-speed copy of 8 seconds (Measured value)/GB
Copy the high-capacity HDD at high speed.
- Copying of only used area (Use area copy function)
Analyze the file system of the source HDD, and copy only the used area to reduce the time required for copying.
The file systems to analyze the used area are FAT, FAT32, NTFS, EXT2 and EXT3.
In addition, this product supports to analyze the used area of the GPT (GUID partition table) used by the HDD larger than 2.2TB.

2 Contents of Product

Here are configurations of this product. Confirm whether or not there are any missing items. If there are any, please contact our agency.

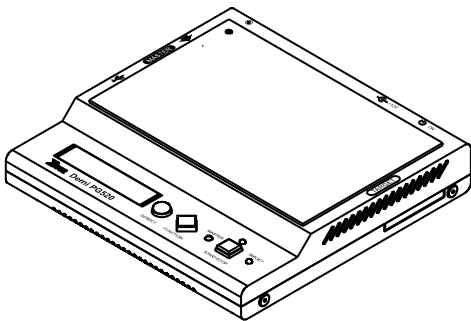

□ Demi PG520 (1)



□ AC Adapter [Y-7173] (1)

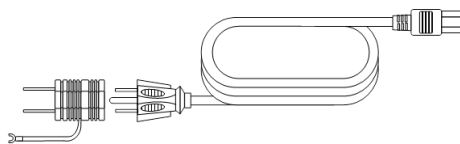

□ AC Code (AC3P-2P conversion connector)
[Y-7190] (1)



□ Operation Manual (1 CD)

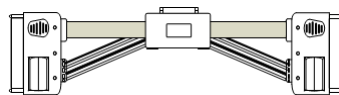

□ SATA Interface Cable [Y-7051] (2)

□ Product Warranty and Inspection
Certificate (1)

3 Name of Parts

3.1 Top Side

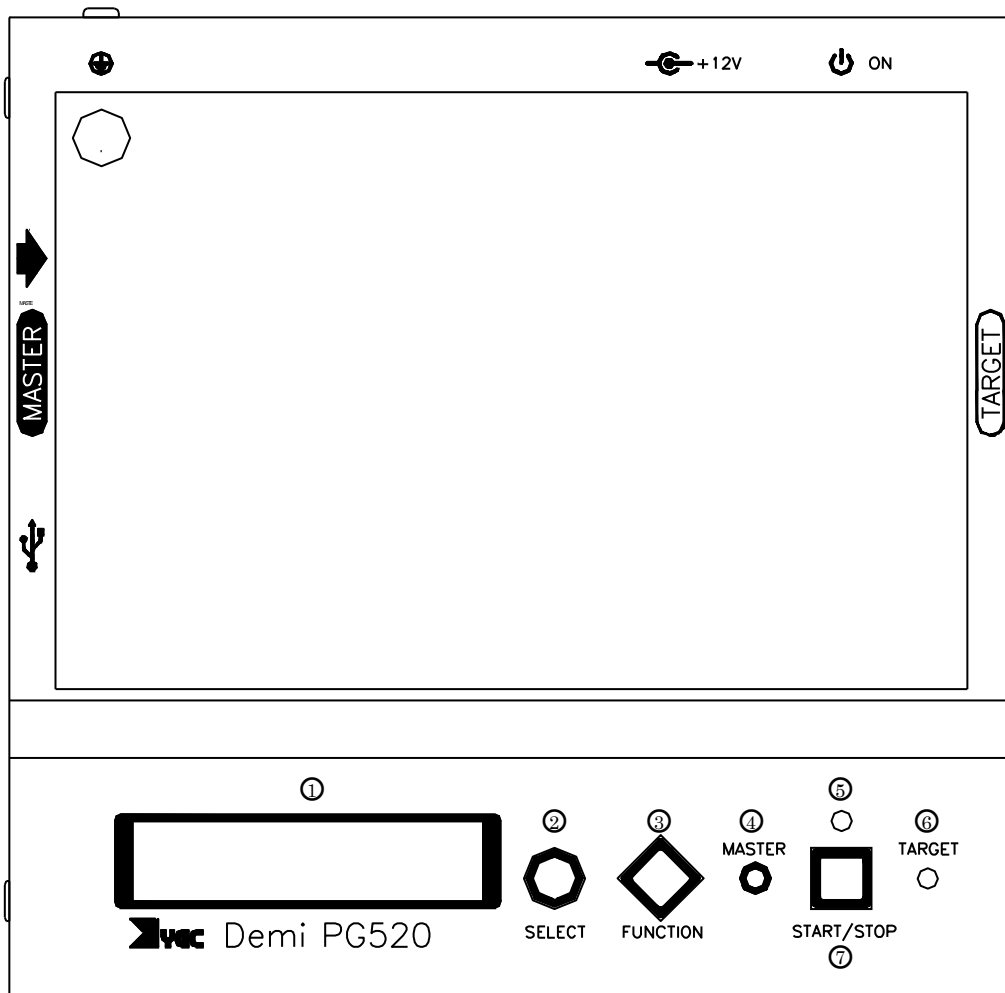

Figure 1 Top side

Name	Descriptions
(1) LCD	Display the operating status of the product.
(2) [SELECT] switch	Use to change the item. Hereinafter referred to as the [SELECT] switch.
(3) [FUNCTION] switch	Use to change the function. Hereinafter referred to as the [FUNCTION] switch.
(4) Access LED (MASTER port)	Display the access status of MASTER port.
(5) Status LED	Use to display the execution result etc.
(6) Access LED (TARGET port)	Display the access status of TARGET port.
(7) [START]/[STOP] switch	Use to display the execution result etc. Hereinafter referred to as the [START] or [STOP] switch.

3.2 Back Side

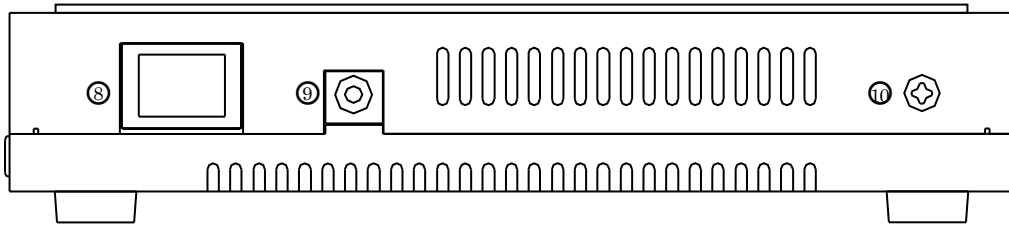

Figure 2 Back side

Name	Descriptions
(8) Power switch	Use to power on/off this product.
(9) DC jack	Connect the DC jack of the AC adapter.
(10) Ground terminal	Connect the ground wires.

3.3 Left Side

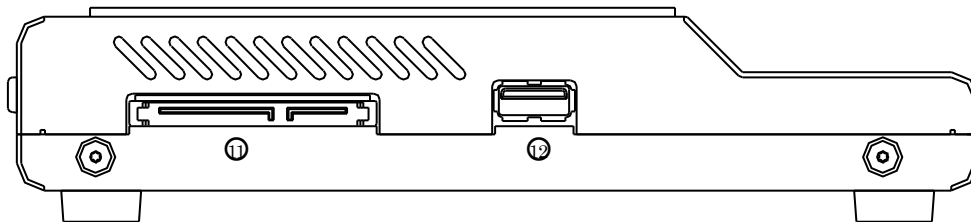

Figure 3 Left side

Name	Descriptions
(11) SATA connector (MASTER port)	Connect the SATA cable to be connected to the source HDD.
(12) USB connector	Connect the USB memory to upgrade the firmware.

3.4 Right Side

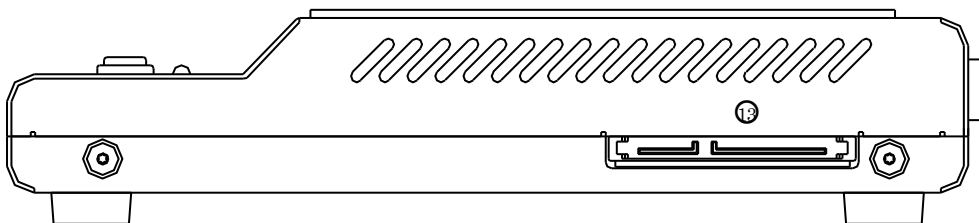



Figure 4 Right side

Name	Descriptions
(13) SATA connector (TARGET port)	Connect the SATA cable to connect to the destination HDD.

4 Operating Procedures

Here are operating procedures of this product taking the procedures to copy or to compare the HDD for example.

 **Execute the processing up to the following section (3) under the condition that the power switch of this product is turned off.**

- (1) Connect the AC cable to the AC adapter.
- (2) Connect the DC jack of the AC adapter to this product.
- (3) Connect the power plug of the AC cable to the AC power source.
- (4) Turn the power switch on as follows.

**U-Boot 2009.06-p17
Board:YE10098A Rev. A**

Screen 1 Start screen

- (5) After displayed as the Screen 1, when the Item selection screen is displayed as follows, the power-on is complete.

**D01:ALL CPY&CMP
READY TO START!**

Screen 2 Item selection screen

- (6) Connect the source HDD and MASTER port using the SATA interface cable.

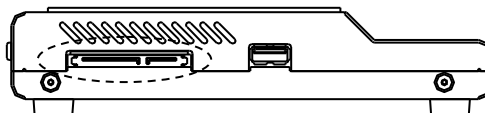

Figure 5 Source HDD connection

- (7) Connect the destination HDD and TARGET port using the SATA interface cable.

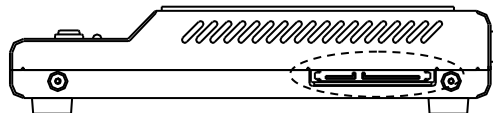

Figure 6 Destination HDD connection

- (8) Confirm the name of the selected item. When the [D01:ALL CPY&CMP] is displayed as the item name, skip to the procedure (13).

**D01:ALL CPY&CMP
READY TO START!**

Screen 3 Item name check

- (9) Push the [FUNCTION] switch to display the Function selection screen. When the [01:DUPLICATE] is displayed as the function name, skip to the procedure (12).



FUNCTION SELECT
01:DUPLICATE

Screen 4 Function selection screen

- (10) Push the [SELECT] switch and the function name will be changed. Push several times until the [01:DUPLICATE] is displayed.



FUNCTION SELECT
01:DUPLICATE

Screen 5 Select [01:DUPLICATE].

- (11) Push the [START] or [STOP] switch and the Item selection screen of the [02:DUPLICATE] function will be displayed.



D01:ALL CPY&CMP
READY TO START!

Screen 6 Item selection screen

- (12) Push the [SELECT] switch and the item name will be changed. Push this switch several times until the [D01:ALL CPY&CMP] is displayed.



D01:ALL CPY&CMP
READY TO START!

Screen 7 Select [D01:ALL CPY&CMP].

- (13) Push the [START] or [STOP] switch to start copying/comparing. While copying/comparing, the Item execution screen is displayed as follows. For details, refer to the section **5.8.2 Item execution screen**.



D01:ALL CPY&CMP
00: 0.4% 66.0MB/s

Screen 8 Item execution screen

- (14) When copied/compared normally, the Item execution end screen is displayed as follows. For details of Item execution end screen, refer to the chapter **5.8.3 Item execution end screen**.

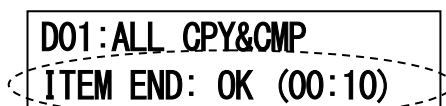

D01:ALL CPY&CMP
ITEM END: OK (00:10)

Screen 9 Item execution end screen(OK)

That's the end of the procedures to copy/compare.

For functional details, refer to the chapter **5 Functions** エラー! 参照元が見つかりません。.

5 Functions

5.1 Duplicate (DUPLICATE)

With this function, the data of the HDD connected to MASTER port can be copied/compared for the HDD connected to TARGET port.

To execute the item of this function, TARGET HDD capacity should be the same or more than MASTER HDD capacity. In addition, the sector length of MASTER HDD should be equal to the one of TARGET HDD.

Table 1 Copy item list

No.	Item name	Descriptions
D01	ALL CPY&CMP	Copy the data in total area of MASTER HDD to TARGET HDD. And compare them.
D02	ALL COPY	Copy the data in total area of MASTER HDD to TARGET HDD.
D03	ALL COMPARE	Compare the data in total area of MASTER HDD with TARGET HDD.
D04	SKIP COPY	Skipping the errors, copy the data in total area of MASTER HDD to TARGET HDD.
D05	FS CPY&CMP	Copy only the data in the used area of MASTER HDD to TARGET HDD to compare.
D06	FS COPY	Copy only the data in the used area of MASTER HDD to TARGET HDD.
D07	FS COMPARE	Compare the only the data in the used area of MASTER HDD with TARGET HDD.

5.2 Capacity Setting (CLIP)

With this function, cancel the HDD capacity connected to TARGET port equal to the HDD capacity connected to MASTER port to return to the default capacity of the HDD.

When executing the item of this function, the capacity is not set for the HDD without HPA function support.

Table 2 Capacity setting item list

No.	Item name	Descriptions
C01	HPA AUTO CLIP	With the HPA function, make TARGET HDD capacity same as MASTER HDD capacity.
C02	HPA CLIP OFF	Cancel the capacity set by the HPA function set to TARGET HDD. In addition, since it is impossible to cancel the capacity set by the DCO function, use our Demi XG series or Hit XG series etc. to cancel the capacity set by the DCO function.

5.3 Data Erasing (ERASE)

With this function, the data of the HDD connected to TARGET port can be erased. By changing the parameter setting, it is also possible to erase the data of the HDD connected to MASTER port.

Table 3 Data erasing item list

No.	Item name	Descriptions
E01	ONE-TIME ERASE	Overwrite the data in total area of TARGET HDD with the fixed value once.
E02	NSA ERASE	Overwrite the data in total area of TARGET HDD with the random values twice, with 0000h once.
E03	DoD ERASE	Overwrite the data in total area of TARGET HDD with the fixed values once, with the reversed fixed values once, and with the random values once to compare the data.
E04	SECURITY ERASE	Perform the secure erase with the [SECURITY ERASE UNIT] command.
E05	ERASE DATA CHECK	Confirm that the fixed value data is written into TARGET HDD.

5.4 Simple Diagnosis (TEST)

This is the simple diagnosis function for the connected HDD. By changing the parameter setting, it is also possible to perform the simple diagnosis of the HDD connected to MASTER port.

Table 4 Simple diagnosis item list

No.	Item name	Descriptions
T01	SELF TEST(SHT.)	Perform the S.M.A.R.T self-diagnosis of TARGET HDD in the short mode. To execute this item when connecting the HDD with no S.M.A.R.T function support, or the HDD with the S.M.A.R.T function support but with no S.M.A.R.T self-test function support, an error is generated.

5.5 HDD Information Display (INFORMATION)

This function provides the information of the connected HDD or the error information.

Table 5 Information display item list

No.	Item name	Descriptions
I01	DEVICE SENSE	Acquire the information of the HDD to display.
I02	DEVICE INFO	Display the information of the acquired HDD.
I03	ERROR INFO	Display the error generated at item execution.

5.6 Operation Setting (CONFIG)

The parameter setting enables to change the operation of this product. Here are settable parameters.

Table 6 Operation setting parameter list

No.	Parameter name	Descriptions	
01	LANGUAGE	The language used in this product.	
		Default	ENGLISH
		Selection	ENGLISH
02	POWER ON WAIT	Specify the waiting time after power-on. (Unit: Sec)	
		Default	20 sec
		Range	0 ~ 99 sec
03	POWER ON INTERVAL	Specify the power-on interval of each channel (Unit: Sec)	
		Default	1 sec
		Range	0 ~ 99 sec
04	BLOCK SIZE	Specify the number of sectors to transfer the data at once. (Unit: Sector)	
		Default	2048
		Range	1 ~ 16384
05	ERROR SKIP	In case of errors, specify whether or not to skip.	
		Default	DISABLE
		Selection	DISABLE / ENABLE
06	CAPACITY CHECK	Specify the capacity condition when copying the disks.	
		Default	>= TOTAL SECS. (Total sectors or more)
		Selection	>= TOTAL SECS. (Total sectors or more) >= PARTITION END (Ensured area or more) >= MINIMUM SECS (Minimum capacity or more)
07	FS DETECTION	Specify whether or not to use MBR information when evaluating the file system.	
		Default	FOLLOW MBR
		Selection	FOLLOW MBR / IGNORE MBR
08	ERASE PATTERN	Specify the fixed value to use for data erasing. (hex value)	
		Default	0000
		Range	0000 ~ FFFF
09	ERASE MASTER	Specify whether or not to erase MASTER HDD when erasing the data.	
		Default	DISABLE
		Selection	DISABLE / ENABLE
10	TEST MASTER	In case of simple diagnosis, specify whether or not to perform the simple diagnosis of MASTER HDD.	
		Default	DISABLE
		Selection	DISABLE / ENABLE
11	SECURITY ID	Specify the type of the security password. For details, refer to the ATA specification	
		Default	USER
		Range	USER / MASTER
12	SECURITY LEVEL	Specify the level of the security password. Available only in the case of security set password. For details, refer to the ATA specification	
		Default	MAXIMUM
		Range	MAXIMUM / HIGH

13	ENHANCED ERASE	Specify the operation of erase mode for the secure erase. Available only in the case of security erase. For details, refer to the ATA specification
		Default DISABLE
		Range DISABLE / ENABLE
14	ATA TRANSFER	Specify the transfer mode of ATA HDD.
		Default AUTO
		Selection AUTO / PIO / MDMA / UDMA
15	ATA TIMEOUT	Specify the time-out value when issuing ATA command. (Unit: Sec)
		Default 30
		Range 0 ~ 9999
16	SWITCH PUSH BEEP	Specify "ON" or "OFF" of the push sound when pushing the switch.
		Default ENABLE
		Selection DISABLE / ENABLE
17	PROGRESS TYPE	Specify how to display the progress.
		Default RATE
		Selection RATE / POSITION / TIME
18	SYSTEM VERSION	Display the software version of this product.
19	FIRMWARE UPDATE	Upgrade the software of this product.
20	PARAMETER LOAD	Read the parameter value stored in the embedded memory.
21	PARAMETER DEF.	Set the parameter value to the factory setting.
22	PARAMETER SAVE	Save the current parameter value to the embedded memory.

5.6.1 Parameter Setting

There are 2 types of selection type and numerical type in the parameter setting. For details, refer to the Table 6 Operation setting parameter list.

5.6.1.1 How to set Selection-based parameter

Here are setting procedures based on the example of the [03:ERROR SKIP] with the Selection-based parameter.

- (1) Push the [FUNCTION] switch to display the Function selection screen.

FUNCTION SELECT
01 : DUPLICATE

Screen 10 Function selection screen

- (2) Push the [SELECT] switch and the function name will be changed. Until the [06:CONFIG] is displayed, push the switch several times.

FUNCTION SELECT
06 : CONFIG

Screen 11 Select [06:CONFIG]

- (3) Push the [START] or [STOP] switch and the Parameter selection screen of the [06:CONFIG] function will be displayed.

CONFIG
01:POWER ON WAIT

Screen 12 Parameter selection screen

- (4) Push the [SELECT] switch and the parameter name will be changed. When the [03:ERROR SKIP] parameter is displayed, push the switch several times.

CONFIG
03:ERROR SKIP

Screen 13 Select [03:ERROR SKIP]

- (5) Push the [START] or [STOP] switch and the Parameter selection screen of the [3:ERROR SKIP] parameter will be displayed as follows.

ERROR SKIP
[DISABLE]

Screen 14 Parameter selection screen

- (6) Push the [SELECT] switch and the parameter value will be changed. When the [ENABLE] is displayed for the parameter value, push the switch several times.

ERROR SKIP
[ENABLE]

Screen 15 Select [ENABLE]

- (7) To fix the parameter value, push the [START] or [STOP] switch. To cancel the selected parameter value, push the [FUNCTION] switch.

5.6.1.2 How to set numerical parameters

Here are procedures to set the numerical parameter taking the [01:POWER ON WAIT] for example. There are 2 types of the digit selection status and the numerical selection status while setting the numerical parameter.

- Digit selection status

Under the digit selection status, move a cursor with the [SELECT] switch. And the number at the cursor position will blink. In this case, push the [START] or [STOP] switch to put into the numerical selection status. In addition, when a cursor is put on the [CANCEL] or [OK], the mark ">" is displayed on the left for each item.

- Numerical selection status

Under the numerical selection status, push the [SELECT] switch to change the value at the cursor position. Push the [START], [STOP] or [FUNCTION] switch and the Digit selection status will be displayed.

- (1) Push the [FUNCTION] switch to display the Function selection screen.



A rectangular box containing the text "FUNCTION SELECT" on the top line and "01:DUPLICATE" on the bottom line.

Screen 16 Function selection screen

- (2) Push the [SELECT] switch and the function name will be changed. Until the [06:CONFIG] is displayed, push the switch several times.



A rectangular box containing the text "FUNCTION SELECT" on the top line and "06:CONFIG" on the bottom line. A dashed oval highlights the "06:CONFIG" text.

Screen 17 Select [06:CONFIG]

- (3) Push the [START] or [STOP] switch and the Parameter selection screen of the [06:CONFIG] function will be displayed.



A rectangular box containing the text "CONFIG" on the top line and "01:POWER ON WAIT" on the bottom line.

Screen 18 Parameter selection screen

- (4) Push the [SELECT] switch and the parameter name will be changed. When the [01:POWER ON WAIT] parameter is displayed, push the switch several times.



A rectangular box containing the text "CONFIG" on the top line and "01:POWER ON WAIT" on the bottom line. A dashed oval highlights the "01:POWER ON WAIT" text.

Screen 19 Select [01:POWER ON WAIT]

- (5) Push the [START] or [STOP] switch and the Parameter selection screen of the [01:POWER ON WAIT] parameter will be displayed.

POWER ON WAIT		
[20]	NO	YES

Screen 20 Parameter selection screen

- (6) With the [SELECT] switch, put a cursor on the digit for number change. And the number at the cursor position will blink.

POWER ON WAIT		
[20]	NO	YES

Screen 21 Cursor on the digit for number change

- (7) Push the [START] or [STOP] switch to put into the numerical selection status. Under the numerical selection status, the number at the cursor position will blink.

- (8) With the [SELECT] switch, select the number to be set.

POWER ON WAIT		
[10]	NO	YES

Screen 22 Select the number for setting

- (9) Push the [START], [STOP] or [FUNCTION] switch to put into the digit selection status. Under the digit selection status, the number at the cursor position will blink again.

- (10) Move the cursor to fix the parameter value to the [YES]. When the cursor is put on the [YES], the screen is displayed as follows.

POWER ON WAIT		
[10]	NO	>YES

Screen 23 Cursor on the [YES]

- (11) To fix the parameter value, push the [START] or [STOP] switch. To cancel the selected parameter value, push the [FUNCTION] switch.

5.7 LED Lighting

The status LED in the upper portion of the [START] or [STOP] switch at the top of this product is turned on/off according to the status.

Table 7 Status LED lighting status

Status	Lighting status	
Item selection	Lights-out	
Item execution	Green (Blink)	
End of item execution.	Normal end	Green (Light)
	Abnormal end	Red (Light)

The access LED of each port at the top of this product is turned on/off according to the status.

Table 8 Access LED lighting status

Status	Lighting status	
Item selection	Lights-out	
Item execution End of item execution.	Access	Green (Light)
	Errors	Red (Light)
	Others	Lights-out
Status	Normal end	Green (Light)
	Normal end (Error skip processing)	Orange (Light)
	Abnormal end	Red (Light)
	Abnormal end (Stop by the user)	Lights-out
	HDD not selected	Lights-out

5.8 LCD Display

The LED screen at the top of this product is displayed as follows.

5.8.1 Item selection screen

On the Item selection screen, with the [SELECT] switch, select the item to be executed. On the Item selection screen, push the [START] or [STOP] switch and the item will be executed.

To move to the Item selection screen of different functions, push the [FUNCTION] switch to select the function on the Function selection screen.

```
D01:ALL CPY&CMP
      READY TO START!
```

Screen 24 Item selection screen

1st line: Item name

Display the name of the selected item.

2nd line: Message display

When it is possible to execute the item, the message [READY TO START!] flashes.

5.8.2 Item execution screen

On the Item execution screen, push the [START] or [STOP] switch to disconnect executing the item.

```
D01:ALL CPY&CMP
00:  0.4% 66.0MB/s
```

Screen 25 Screen during item execution

1st line: Item name

Display the running item name.

2nd line: Processing contents, Progress status, Error information

Display the processing contents, the progress status and the generated error information.

While the progress status is displayed, each time pushing the [FUNCTION] switch and the progress display will be changed.

```
D01:ALL CPY&CMP
00:  0.4% 66.0MB/s
```

Screen 26 Progress (%)

```
D01:ALL CPY&CMP
00: 4300/ 73407MB
```

Screen 27 Progress (MB)

```
D01:ALL CPY&CMP
00: 0:03:15 0:14:44
```

Screen 28 Progress (Elapsed time/Estimated time left)

5.8.3 Item execution end screen

On the Item execution end screen, push the [START] or [STOP] switch to restore to the item selection status.

D01:ALL CPY&CMP ITEM END: OK (00:10)

Screen 29 Item execution end screen (OK)

D01:ALL CPY&CMP ITEM END: NG (00:06)

Screen 30 Item execution end screen (NG)

1st line: Item name

Display the running item name.

2nd line: Result display

Display the execution result. The contents shown in parentheses mean the time spent in the item execution (Unit: min).

5.8.4 Function selection screen

On the Function selection screen, with the [SELECT] switch, select the function to be executed. On the Function selection screen, push the [START] or [STOP] switch and the Item selection screen of the selected function will be displayed. Push the [FUNCTION] switch and the previous Item selection screen will be redisplayed.

FUNCTION SELECT 01:DUPLICATE

Screen 31 Screen during item execution

1st line: Message display

Display the message "FUNCTION SELECT".

2nd line: Currently-selected function

Display the currently-selected function.

5.8.5 Port selection screen

This section provides the descriptions about the Port selection screen to select the port to display the HDD information or error information when executing the [I01:DEVICE SENSE], [I02:DEVICE INFO] and [I03:ERROR INFO].

On the Port selection screen, with the [SELECT] switch, select the port for information display. On this screen, push the [START] or [STOP] switch and the HDD information display screen or the Error information display screen of the selected port will be displayed. Push the [FUNCTION] switch and the previous Item selection screen will be redisplayed.

I01:DEVICE INFO [MASTER]

Screen 32 Screen during item execution

1st line: Item name

Display the running item name.

2nd line: Currently-selected port

Display the currently-selected port.

5.8.6 HDD information display screen

This section provides the descriptions about the HDD information display screen that is displayed after executing the [I01:DEVICE SENSE] and [I02:DEVICE INFO] to select the display port.

There are total 12 screens on the HDD information display screen. The display is different for each page of the HDD information.

Here are display contents of each page and the operation when the switch of each page is pushed.

Table 9 Switch on HDD information display screen

Switch	Operation
[SELECT] switch	The next page is displayed. When this switch is pushed in the last page, the top page is displayed.
[FUNCTION] switch	Return to the Port selection screen.
[START]/[STOP] switch	Return to the Port selection screen.

5.8.6.1 Page 1 - Model name

MODEL_NUMBER: Hitachi HDS723030ALA

Screen 33 Model name

1st line: Information name

Display the MODEL_NUMBER.

2nd line: Device model name

Scroll the device model name to the left for display.

5.8.6.2 Page 2 - Serial No.

SERIAL_NUMBER: MK0311YHG3VBEA
--

Screen 34 Serial No.

1st line: Information name

Display the "SERIAL_NUMBER".

2nd line: Media information

Display the device serial No.

5.8.6.3 Page 3 - Firmware revision No.

FIRMWARE_VERSION: MKA0A580

Screen 35 Firmware revision No.

1st line: Information name

Display the FIRMWARE_VERSION.

2nd line: Media information

Display the Firmware revision No. of device.

5.8.6.4 Page 4 -Transfer mode support status (PIO/MDMA)

PIO :0/1/2/3/4 MDMA:0/1/2
--

Screen 36 Transfer mode support status (PIO/MDMA)

1st line: PIO transfer mode support status

Display the PIO transfer mode support status.

2nd line: Multiword DMA transfer mode support status

Display the Multiword DMA transfer mode support status. When the Multiword DMA transfer mode is unsupported, "NOT_SUPPORT" is displayed.

5.8.6.5 Page 5 -Transfer mode support status (Ultra DMA)

UDMA:0/1/2/3/4/5/6

Screen 37 Transfer mode support status (Ultra DMA)

1st line: Ultra DMA transfer mode support status

Display the Ultra DMA transfer mode support status. When the Ultra DMA transfer mode is unsupported, "NOT_SUPPORT" is displayed.

2nd line: Unused

5.8.6.6 Page 6 - Capacity information (CHS)

CHS :16383/16/ 63
SIZE : 8455MB

Screen 38 Capacity information (CHS)

1st line: Geometry information

Display the geometry information in CHS mode of the device.

2nd line: Capacity

Display the capacity in CHS mode in MB by the 10-digit decimal value.
In addition, 1MB is for 1,000,000 bytes.

5.8.6.7 Page 7 - Capacity information (LBA28)

LBA28:SUPPORT
SIZE : 137438MB

Screen 39 LBA28 mode supported

LBA28:NOT SUPPORT

Screen 40 LBA28 mode unsupported

1st line: LBA28 mode support status

Display LBA28 mode support status.

2nd line: Capacity

Display the capacity in LBA28 mode in MB by the 12-digit decimal value.
In addition, 1MB is for 1,000,000 bytes. When LBA28 mode is unsupported, nothing is displayed.

5.8.6.8 Page 8 - Capacity information (LBA48)

LBA48:SUPPORT
SIZE : 3000592MB

Screen 41 LBA48 mode supported

LBA48:NOT SUPPORT

Screen 42 LBA48 mode unsupported

1st line: LBA48 mode support status

Display LBA48 mode support status.

2nd line: Capacity

Display the capacity in LBA48 mode in MB by 12-digit decimal values. In addition, 1MB is for 1,000,000 bytes. When LBA48 mode is not supported, nothing is displayed.

5.8.6.9 Page 9 - Capacity information (HPA)

HPA :SUPPORT, ON SIZE : 3000592MB	HPA :SUPPORT, OFF SIZE : 3000592MB
Screen 43 ENABLE	Screen 44 DISABLE
HPA :NOT SUPPORT	
Screen 45 Non-supported	

1st line: HPA function support status and effective status

Display the support status and effective status of the HPA function.

2nd line: Capacity

Display the capacity when the HPA function is disabled in MB by 12-digit decimal values.

In addition, 1MB is for 1,000,000 bytes. When the HPA function is unsupported, nothing is displayed.

5.8.6.10 Page 10 - Capacity information (DCO)

DCO :SUPPORT, ON SIZE : 3000592MB	DCO :SUPPORT, OFF SIZE : 3000592MB
Screen 46 ENABLE	Screen 47 DISABLE
DCO :NOT SUPPORT	
Screen 48 Non-supported	

1st line: DCO function support status and effective status

Display the support status and effective status of the DCO function.

2nd line: Capacity

Display the capacity when the DCO function is disabled in MB by 12-digit decimal values.

In addition, 1MB is for 1,000,000 bytes. When the DCO function is unsupported, nothing is displayed.

5.8.6.11 Page 11 - S.M.A.R.T function support status

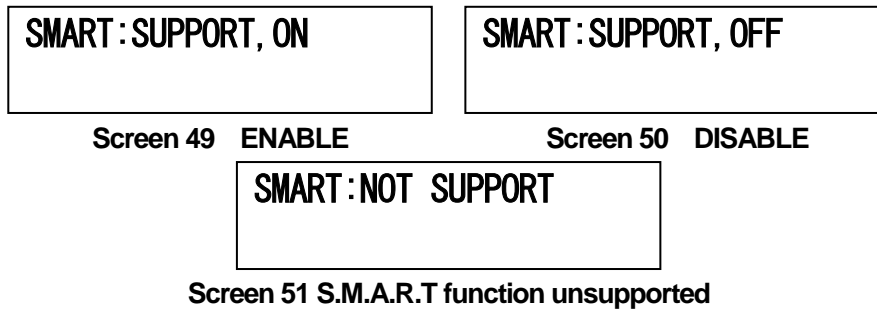

1st line: S.M.A.R.T function support status and effective status

Display the support status and effective status of S.M.A.R.T function.

2nd line: Unused

5.8.6.12 Page 12 - Security function support status

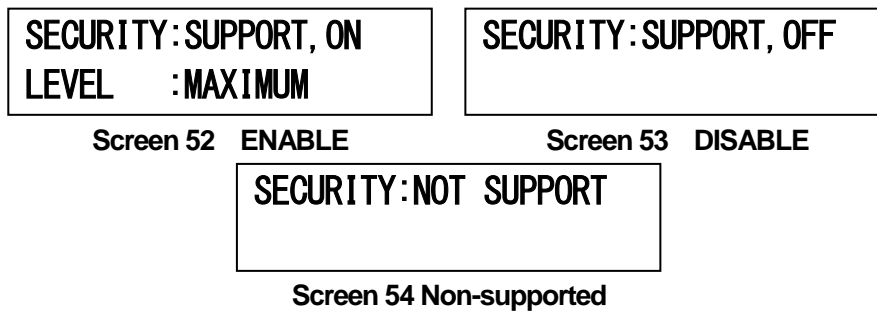

1st line: Security function support status and effective status

Display the support status and effective status of the security function.

2nd line: Security level

Display the level when the security function is [ENABLE]. When the security function is unsupported or [DISABLE], nothing is displayed.

5.8.7 Error information display screen

This section provides the descriptions about the Error information display screen displayed after executing the [I03:ERROR INFO] to select the display port.

There are total 3 screens on the Error information display screen. The display is different for each page of the Error information. Here are descriptions about display contents of each page.

In addition, here are operations when pushing the switch.

Table 10 Switch on Error information screen

Switch	Operation
[SELECT] switch	The next page is displayed. When this switch is pushed in the last page, the top page is displayed.
[FUNCTION] switch	Return to the Port selection screen.
[START]/[STOP] switch	Return to the Port selection screen.

5.8.7.1 Page 1 - Error message

E42:ABORT
CMD:DEVICE CONFIG

Screen 55 Error information display

1st line: Error information

The error code and messages are displayed.

2nd line: Command in case of errors

Display the ATA command name in case of errors. In addition, if the error is other than the errors caused by executing ATA command, nothing is displayed.

5.8.7.2 Page 2 - Command information

CMD:B1 FEA:C0 D/H:00
LB: 0000000, 00

Screen 56 Command information display (CHS/LBA28)

CMD:B1 FEA:C0 D/H:00
LB:000000000000, 0000

Screen 57 Command information display (LBA48)

1 - 2nd line: Command parameter in case of errors

Display the command parameter of ATA command in case of errors. In addition, if the error is other than the errors caused by executing ATA command, "-" is displayed for each digit.

5.8.7.3 Page 3 - Error status

STA:51 FEA:04 D/H:00 LB: 0000000, 00

Screen 58 Error status (CHS/LBA28)

CMD:51 FEA:04 D/H:00 LB:000000000000, 0008

Screen 59 Error status (LBA48)

1 - 2nd line: Error status

Display the error status of ATA command in case of errors. In addition, if the error is other than the errors caused by executing ATA command, "-" is displayed for each digit.

5.8.7.4 Error code list

Here are error codes of this product.

No.	Message	Descriptions
E00	NO ERROR	No error
E01	SELECTION FAIL	Interface selection failed
E02	DEVICE NOT FOUND	Device unconnected
E03	SET TRNS MD FAIL	Transfer mode setting failed
E04	SET ACCS MD FAIL	Access mode setting failed
E05	COMMAND ERROR	Command execution failed
E06	COMMAND TIMEOUT	Time-out at command execution
E07	RETRY CNT EXPIRE	Retry count reached a maximum count.
E08	COMPARISON FAIL	Master HDD data and Target HDD data mismatched
E10	NOT ENOUGH CAP.	The capacity of TARGET HDD is less than the one of MASTER HDD.
E11	BLK LEN UNMATCH	The sector length of Master HDD and Target HDD is mismatched.
E20	MST SIZE UNKNOWN	Master HDD Capacity unknown
E30	HPA UNSUPPORT	HPA function unsupported
E33	SMART UNSUPPORT	S.M.A.R.T function unsupported
E35	SLFTST UNSUPPORT	S.M.A.R.T Self-Test unsupported
E36	HPA FAIL	HPA processing failed
E40	AM ERROR	Address mark not found
E41	TRACK0 ERROR	Track 0 not found
E42	ABORT	Command processing stop by the device
E43	MEDIA CHG REQ	Media removal request generated
E44	ID ERROR	Sector ID not found
E45	MEDIA CHANGED	Media insertion generated
E46	UNCORRECTABLE ER	Uncorrectable errors generated
E47	UDMA CRC ERROR	UDMA CRC errors generated
E48	SECURITY ERROR	Command processing stop by the security function

6 Glossary

ATA

This means an abbreviation for AT Attachment. It is one of the HDD interface standards for the PC.

The parallel bus is used and 2 HDDs can be connected to one bus for achieving the transfer rate of the maximum 133MB/sec (Theoretical value). Currently, it is being replaced by SATA using High-speed serial interface.

CHS addressing

This is the system to specify the sector position using Cylinder No., Head No. and Sector No. based on the internal structure of the disk. It was used by the early IDE HDD. Because of Cylinder No.16383, Head No.16 and Sector No.63 as the upper limit of each parameter, maximum capacity displayed by CHS was about 8.4GB. Since it was impossible to change with the high-capacity HDD, it was less and less used after LBA was installed. At present, it is remained to maintain compatibility with old systems.

DCO

This means an abbreviation for Device Configuration Overlay. It is determined by ATA specification. The user access to the data in the HDD specified area or the HDD functions can be limited.

EXT2

This means an abbreviation for Second Extended File System. It is the file system primarily used by the Linux system.

EXT3

This means an abbreviation for Third Extended File System. It is the file system primarily used by the Linux system. This is compatible with EXT2 including the journaling function.

FAT

This means an abbreviation for File Allocation Table. It is one of the file systems developed by Microsoft.

Originally, FAT was the area to register the file position in the disk. But gradually, it came to mean the very file system. In addition, it has become popular with use as MS-DOS file system. And it is still used by various devices. There are some types (FAT12, FAT16, FAT32 etc.) based on the bit number for the management domain.

GPT

This means an abbreviation for GUID Partition Table. It is the partition information registration system defined by EFI specification aiming for replacement of the existing MBR. Since the HDDs more than 2.2TB that cannot be managed by MBR are marketed and the PCs are corresponding to UEFI specification, this system will be widely used in the future.

HPA

This means an abbreviation for Host Protected Area. It is determined by ATA specification. The user access to the data in the specified area of the HDD is limited.

IDE

This means an abbreviation for Integrated Drive Electronics. It is one of the HDD interfaces for the PCs. Since it was used and uniquely extended by each HDD manufacturer, the compatibility fault was generated. Therefore, it was standardized as “ATA-1” by ANSI after setting ATA as the common specification.

LBA

This means an abbreviation for Logical Block Addressing. Unlike in the case of CHS addressing, this system represents the sector position not by the multiple parameters depending on the internal structure of the disk but by one logical parameter other than the internal structure of the disk. At the beginning of the installation, LBA address bit of ATA HDD was 28 bits and the maximum capacity was about 137GB. After that, the HDD capacity has been increased additionally, the address bit with the installed LBA48 mode is 48 bits and the maximum capacity is 144PB.

MBR

This means an abbreviation for MASTER Boot Record. It is in the top sector of the HDD to record the OS boot program or the partition information in the HDD.

Since the maximum capacity for MBR partition information is 2.2TB, if using the HDD of 2.2TB or more, the partition information is recorded by GPT.

NTFS

This means an abbreviation for NT File System developed by Microsoft. It is one of the file systems developed as the new file system to cover the flaws of FAT that is MS-DOS file system, or HPFS that is OS/2 file system. This is the Windows file system that is currently main OS of Microsoft.

SATA

This means an abbreviation for Serial ATA. It is one of the HDD interface standards for the PCs. Unlike in the case of the existing ATA, the faster transfer happened by using the high-speed serial interface.

The maximum transfer rate from the development start was 150MB/sec (Theoretical value). With the upgrade of standards, maximum transfer rate has reached 600MB/sec (Theoretical value).

S.M.A.R.T

This means an abbreviation for Self-monitoring, analysis, and reporting technology.

It is specified by ATA specification. With this function, the HDD itself performs the monitoring of the internal status for the status notice.

7 Product Specification

Outer dimension	W175 x D171 x H31 (Mm) * Exclusive of protrusions
Weight	650g (Main unit)
Power requirements	AC adapter 12V 5.0A 60W (AC 100V ~ 240V, 50Hz/60Hz)
Operating temperature	10 deg C ~ 35 deg C, 30% ~ 80% (No condensation)
HDD interface	SATA x 2 (SATA 3Gbps supported)

Table 11 Demi PG520 Product specification

Demi PG520

**Operation Manual
2nd Edition**

February 2016

Copyright (C) YEC Co., Ltd. 2012-2016 All Rights Reserved.

Inquiries Regarding Our Products

Aim to become the leader of the storage market application

 **YEC Co., Ltd**

<http://www.kk-yec.co.jp/>

We will transmit Technical support for our products or Latest information

543-9, Tsuruma, Machida-City, Tokyo 194-0004 Japan

TEL: 042-796-8511

FAX: 042-796-2367