

# Quick Start Guide

TR54

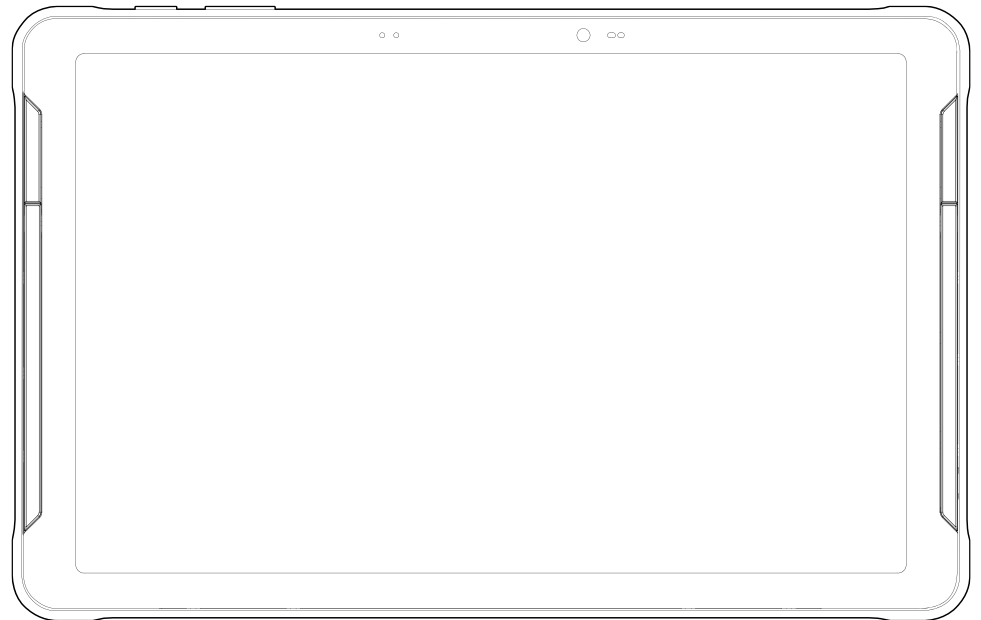

# Tablet Parts

## 45° Scanner SKU

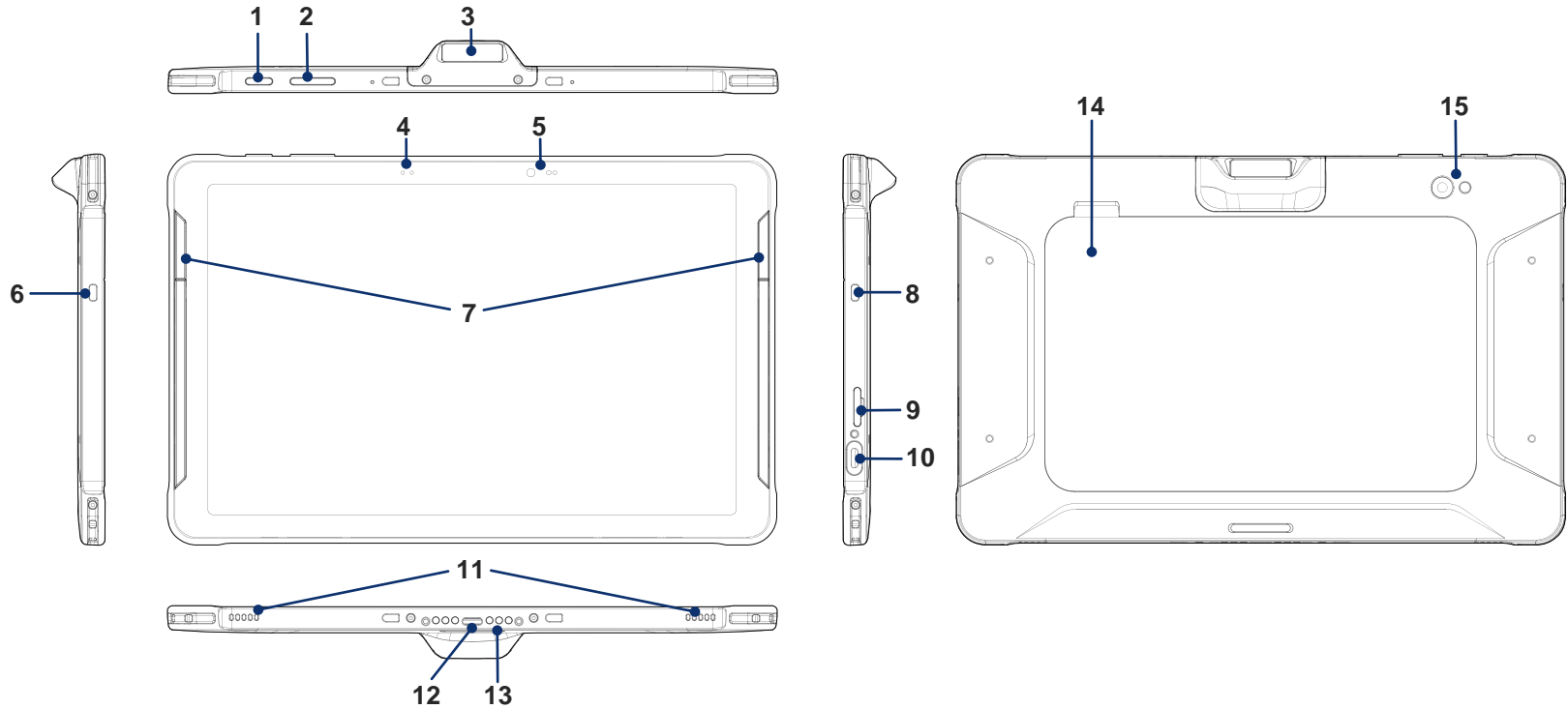

- 1. Power button
- 2. Volume buttons
- 3. Scanner
- 4. LED indicator
- 5. Front camera

- 6. Kensington security slot
- 7. Scan button
- 8. Kensington security slot
- 9. Card tray
- 10. USB connector

- 11. Speaker
- 12. USB connector
- 13. I/O connector for cradle
- 14. Battery cover
- 15. Rear camera & Flashlight

# Tablet Parts

## Straight Scanner SKU

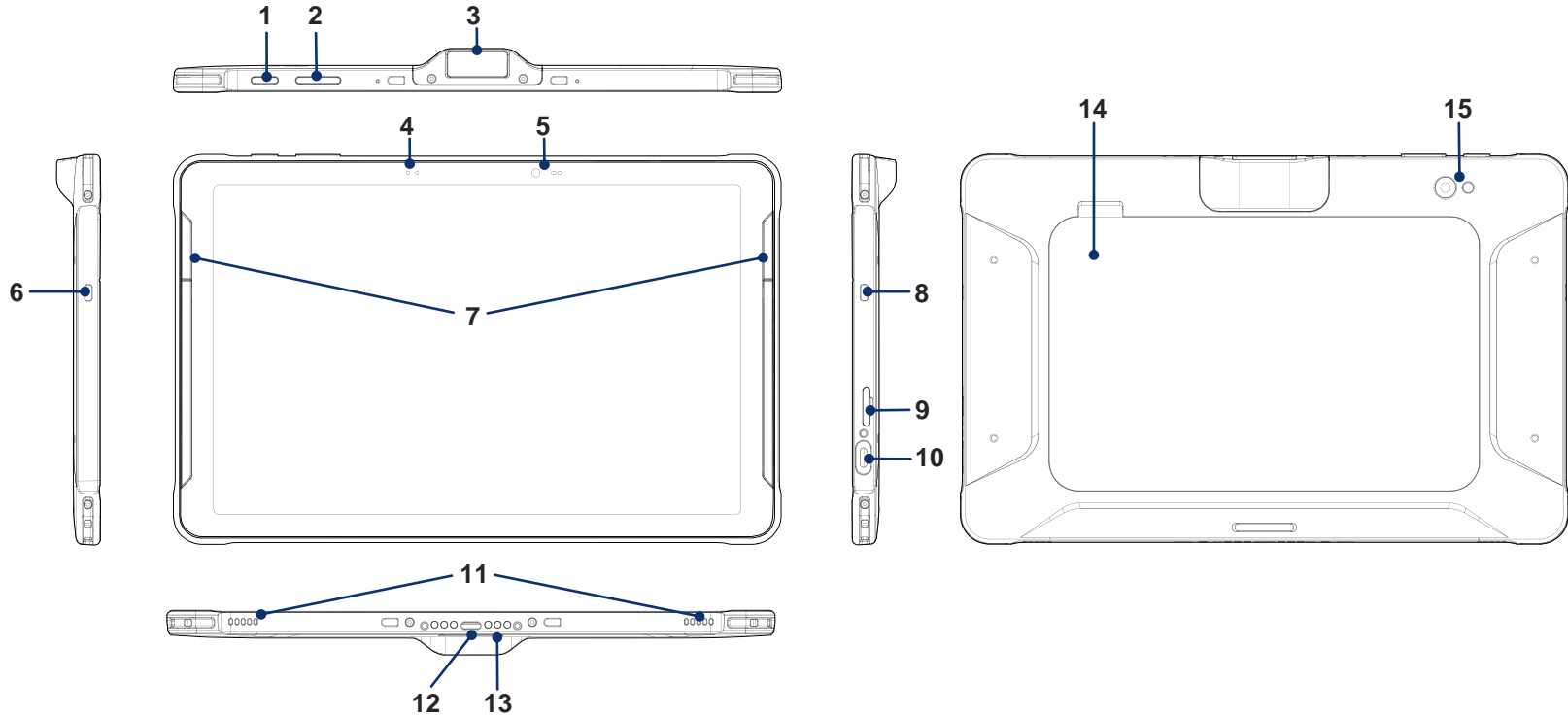

- 1. Power button
- 2. Volume buttons
- 3. Scanner
- 4. LED indicator
- 5. Front camera

- 6. Kensington security slot
- 7. Scan button
- 8. Kensington security slot
- 9. Card tray
- 10. USB connector

- 11. Speaker
- 12. USB connector
- 13. I/O connector for cradle
- 14. Battery cover
- 15. Rear camera & Flashlight

# Tablet Parts

## No Scanner SKU

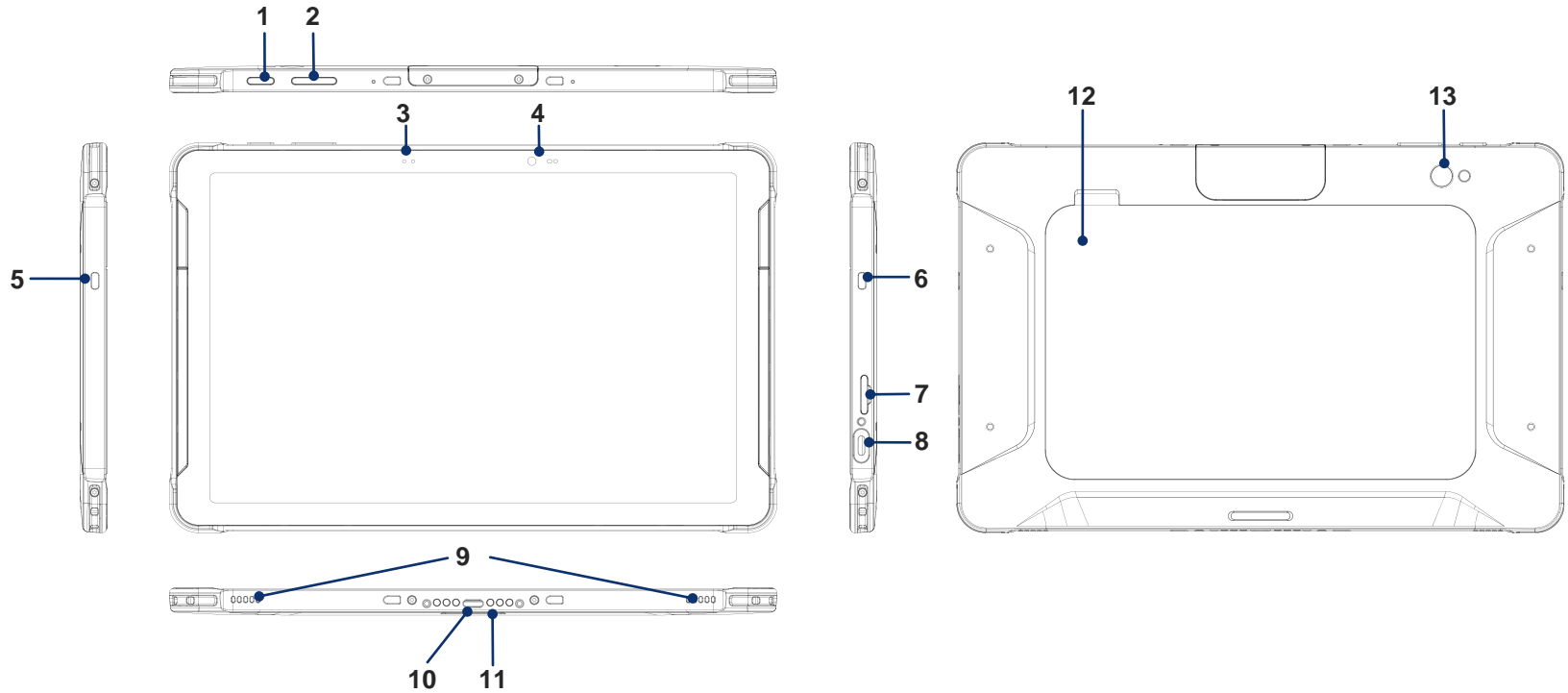

- 1. Power button
- 2. Volume buttons
- 3. LED indicator
- 4. Front camera
- 5. Kensington security slot

- 6. Kensington security slot
- 7. Card tray
- 8. USB connector
- 9. Speaker
- 10. USB connector

- 11. I/O connector for cradle
- 12. Battery cover
- 13. Rear camera & Flashlight

## Product Standard Accessories



Battery pack



AC Plug



Charger



LCD protection film

## Battery Replacement

### Insert Battery

1. Remove the battery cover using the tab at the top.
2. Insert the battery from the top side.
3. Slide the battery lockers to  side.

### Remove Battery

1. Remove the battery cover using the tab at the top.
2. Slide the battery lockers to  side.
3. Remove the battery from the bottom.

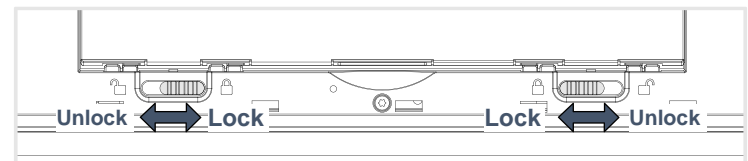
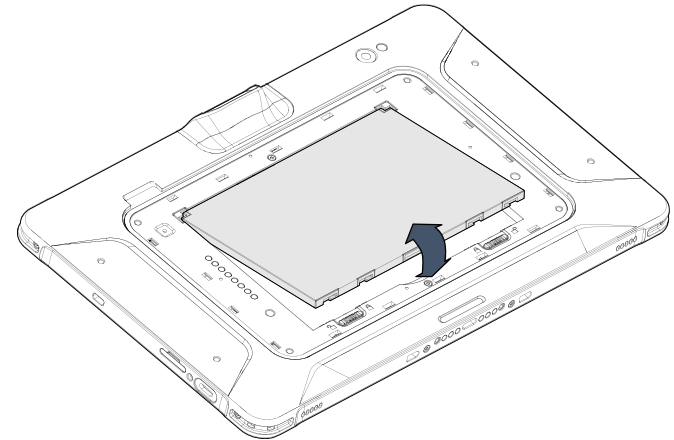

## Install SD / SIM Card

TR54 supports

- Micro SD card
- Nano SIM card (WWAN (LTE) SKU only)

To install SD or SIM card,

1. Pull off the card tray on the right of the tablet.

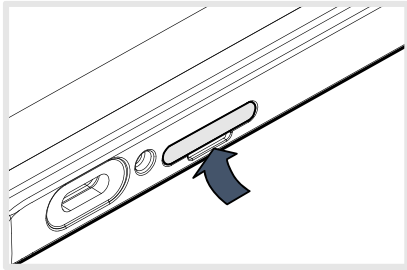

2. Put the proper card with the contacts facing down.
3. Insert the tray.

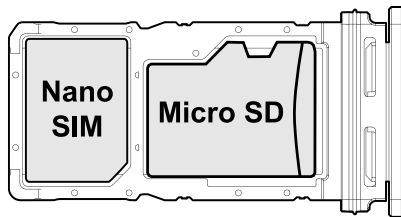

## Turning on / off

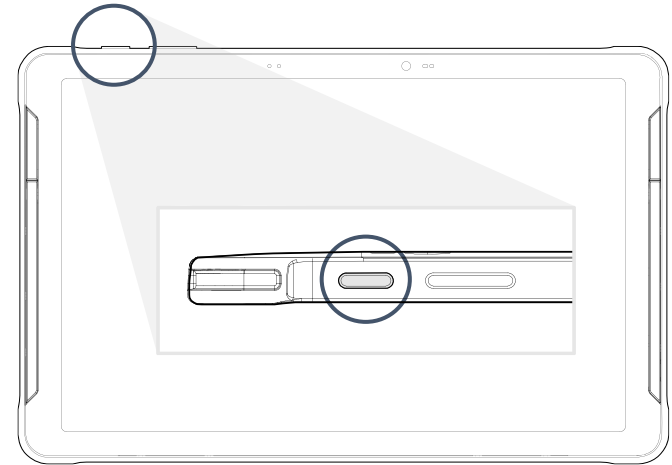

### Turn on

Press and hold the power button on the top until **SMART BEYOND RUGGED** logo displays on the screen.

### Turn off

When the display is on, press and hold the power button until the power menu is shown.

Then, tap **Power off**.

## LED Indicator

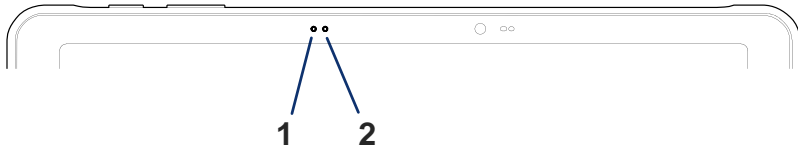

No	Indicator	Status	Indication
1	Power LED	Solid green	Tablet is fully charged
		Solid red	Charging the tablet / Battery is low
		Blinking red	Charging temperature is out of normal range / Battery is very low
		Alternately blinking red & green	Cannot recognize the battery
2	Notification LED	Blinking blue	Notification existing
		Red flash	Barcode reading failed
		Blue flash	Barcode reading success

## Charging the Device

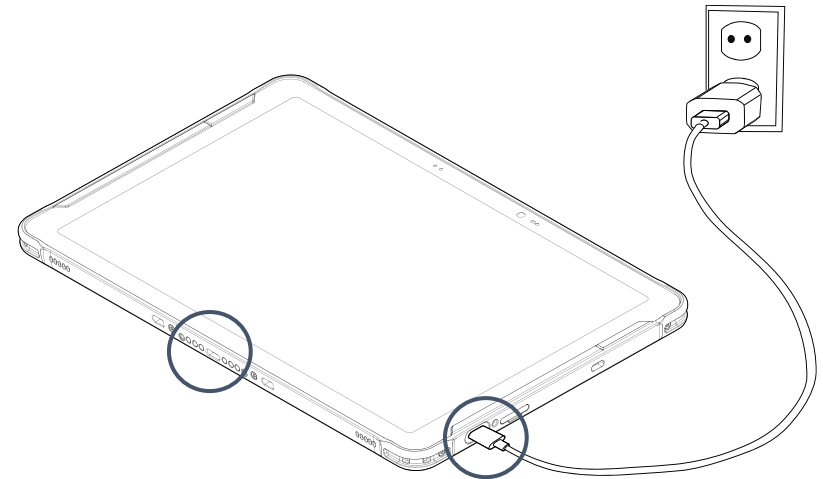

1. Assemble the AC plug, charger, and USB C to C cable.
2. Connect the cable to a USB connectors (Right or Bottom).
3. Provide power by plugging the power adapter to the wall socket.

### < Caution >

1. Always use an original charger or cradle from Point Mobile. Other chargers may damage the TR54. The device warranty does not cover any damage caused by the usage of non-original chargers.
2. Make sure the charger and cable is not wet.
3. Charge in temperatures from 0°C to 45°C.

## Scan a Barcode

### (TR54 with Scanner only)

Scanner is enabled by default, If the scanner is not enabled, you can turn on the scanner from **ScanSettings**.

Check if the scanner icon  is placed on the Status bar. Then, press a scan button on the device to scan a barcode.

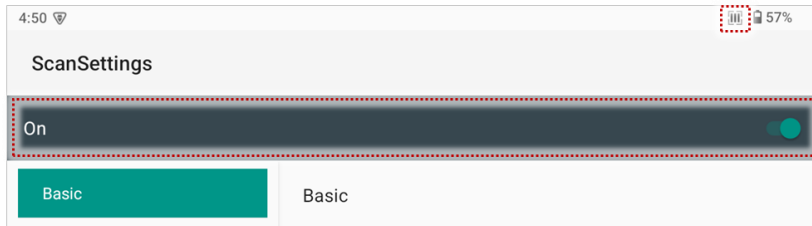

### N5703 Scanner SKU



Center the cross-hair aimer or red dot aimer over the barcode.

### N2601 Scanner SKU



Center the green dot aimer over the barcode.

## Support

- ARS : +82-1800-3010
- FAX : +82-3397-7872
- Address : 26F, Gasan Publik Building A, 178, Digital-ro, Geumcheon-gu Seoul, Korea 08513
- Website : <https://www.pointmobile.com>
- E-mail : [pm\\_ta@pointmobile.com](mailto:pm_ta@pointmobile.com)

## Certification

- Model: TR54
- Trade name of certified: Point Mobile Co., Ltd.
- Manufacturer: Point Mobile Co., Ltd.
- For more certificate information, go to **Settings > About phone > Certificates**.





v0.1, May 2025

Copyright © 2025 POINT MOBILE Co. , Ltd. All rights reserved.

POINT MOBILE Co. , Ltd. is the designer and manufacturer of mobile handheld devices.

The Point Mobile logo is a registered trademark and symbol of POINT MOBILE Co. , Ltd.

Features and specifications are subject to change without prior notice.