

NLS-EM23

Bar code reading engine

Integration manual

Disclaimer

Please read all the contents of this manual carefully before using the products described in this manual to ensure the safe and effective use of the products. After reading this manual, please keep it properly for future reference.

Please do not disassemble the terminal or tear up the seal on the terminal, otherwise Shenzhen Touch Think Intelligence Co., Ltd will not be responsible for warranty or replacement of the terminal.

The pictures in this manual are for reference only. If some pictures are inconsistent with the actual products, please refer to the actual products. For the improvement and update of this product, Shenzhen Touch Think Intelligence Co., Ltd reserves the right to modify the document at any time without notice.

All information contained in this manual is protected by copyright, and Shenzhen Touch Think Intelligence Co., Ltd reserves all rights. Without written permission, no unit or individual may extract, copy or bundle all or part of this document with other products in any form or for any reason.

The products described in this manual may include the copyrighted software of Shenzhen Touch Think Intelligence Co., Ltd . or a third party. No unit or individual may copy, distribute, modify, extract, decompile, disassemble, decrypt, reverse engineer, lease, transfer, sublicense or other acts infringing the software copyright in any form unless the permission of the relevant obligee is obtained.

Shenzhen Touch Think Intelligence Co., Ltd . has the final right to interpret this statement.

Versions of records

version number	Version description	Release date
V1.0.0	Initial version.	2020.07. 27
V1.0.1	Change the 13-PIN in the document to 8-PIN. Update Figure 5-1 and Figure 5-2.	2020.08. 25

Catalogue

Disclaimer	6
brief introduction	1
Chapter outline	1
Symbol description.....	1
introduce	2
Indicator light.....	3
introduce	4
general requirements	4
Dust and pollution prevention.....	4
environment.....	4
Heat dissipation considerations.....	5
Protection of optical devices.....	5
Embedding.....	6
Assembly reference parameters (unit: mm).....	6
External design	7
Optical correlation	7
Window positioning	7
Window material and color.....	9
PMMA.....	9
chemically strength tempered glass.....	9
Window scratch prevention and coating.....	10
Coating requirements	10
Anti-scratch requirements.....	10
Window size.....	11
Figure2-3.....	11
ambient light.....	12
Human eye safety	12
Interface definition.....	13
Connector specifications and dimensions	15
8-PIN DuPont connector.....	15
power requirement	16
Ripple noise.....	16
Dc characteristics	16
operating voltage	16
operational current.....	16
Power sequence.....	18
Power on sequence	18
USB_D+.....	18
nTRIG.....	18
Power-down sequence	21
USB_D+.....	21
nTRIG.....	21
External circuit reference design.....	21
Buzzer reference circuit.....	21
Trigger function reference circuit	22
EasySet.....	23

Brief introduction

EM23 is an ultra-small embedded bar code recognition engine, which adopts CMOS image technology and the latest generation of decoding chips with international advanced level of intelligent image recognition technology in Shenzhen Touch Think Intelligence Co., Ltd .. EM23 can easily read all kinds of bar codes on mobile phone screens, with strong recognition performance and lower power consumption compared with all kinds of code reading engines on the market, which is very suitable for the integration and application of code reading equipment with batteries.

※Note: This guide provides engine installation instructions. Shenzhen Touch Think Intelligence Co., Ltd .suggested that photoelectric mechanical engineers should conduct optical analysis before optical design.

Chapter outline

Chapter 1 About EM23	Introduce the engine module
Chapter II Installation	Provide how to install the engine, including installation information, housing design, optics, grounding, ESD and environmental considerations.
Chapter III Interface	Provides the interface definition, connector specifications and dimensions
Chapter IV Electrical Characteristics	The electrical characteristics, technical specification information and power supply sequence of the engine are provided.
Chapter 5 External Reference Circuits	The design of external driving circuit is provided.
Chapter VI Supporting Tools	Auxiliary tool description

Symbol description

This document is described with the following symbols:

- Indicates the items listed, but not necessarily in order.

Indicate matters needing attention and important contents. ※ Ignoring this information will not cause personal injury to readers or damage to equipment and data.

△ Warning: This symbol indicates that if this information is ignored, data or materials may be damaged, and even personal injury may be caused to readers.

Introduce

EM23 is an ultra-small embedded bar code reading engine, which adopts CMOS image technology and the latest generation of decoding chips with the international advanced level of intelligent image recognition technology in the New World. EM23 can easily read QR codes on the screen, and its power consumption is lower than all kinds of code reading engines on the market, which is very suitable for the integration and application of code reading equipment with batteries.

There are three LED indicators on EM23.



EM23 includes:

- 1 CMOS sensor and lens
- 3 LED lights for positioning

indication Figure 1-1 System

module diagram:

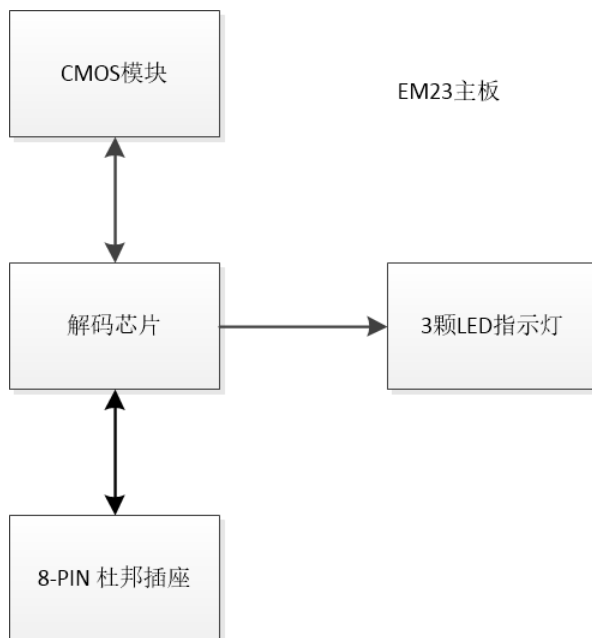

Please check the Chinese translation in the picture here: CMOS module-Decoding chip-8-PIN Dupont socket-3 LED indicators-EM23 Motherboard

EM23 is connected to the host computer through 8-PIN DuPont line. For detailed information about 8-PIN Dupont cable, please refer to Chapter 3, Definition of 8-PIN Dupont Socket.

Indicator light

The indicator light on EM23 is used to indicate the position of the equipment, and consists of three LEDs. When scanning code is started, the LEDs will light up synchronously.



Introduce

This chapter provides information about installing EM23, including physical and electrical information, precautions and recommended EM23 window properties.



general requirements

Electrostatic protection (ESD)

EM23 has designed electrostatic protection, but due to the limitation of module size, the electrostatic protection of the interface signal with the client cannot be handled properly, so the electrostatic protection design of the module should be considered at the client. Anti-static packaging is used in the module, but anti-static measures should still be paid attention to during unpacking and use, such as using grounding wrist strap and grounding the work area.

Dust and pollution prevention

EM23 must be sufficiently sealed during storage and use to prevent dust, particles or other pollutants from gathering and adhering to the lens, circuit board, LED and other components. Dust particles or pollutants will reduce the performance of the engine and even affect the use of the engine.

environment

The normal use of EM23 shall meet the environmental requirements in the following table.

Table2-1:

Working temperature	-20°C to +60°C
Storage temperature	-40°C to +70°C
relative humidity	5% ~95% (no condensation)

Heat dissipation considerations

When the EM23 reading engine is embedded into any product, the heat dissipation design needs to be considered. There are several high-power devices (such as CPU, CMOS power supply, etc.) on the EM23 reading engine, which will emit a lot of heat when working continuously. When the ambient temperature is high, it will increase the image noise of the image sensor, reduce the image quality and affect the reading performance.

In the integrated application, the heat of EM23 can be reduced in the following ways:

- In the design, the space for EM23 to form natural convection or forced convection is reserved.
- Avoid using rubber and other heat insulation materials to tightly wrap EM23.

Protection of optical devices

In the integrated application, the window should be designed to prevent the lens surface from contacting with pollutants such as dust, liquid or grease. These substances may not only affect the optical path, but also damage the lens, thus affecting the reading efficiency.

During installation and use, please don't let anything touch the lens surface to prevent scratching and polluting the lens; The operator should avoid talking to the lens and keep pollutants away from the working environment as much as possible;

If the lens surface is polluted, you can first blow the lens surface with a blowing ball (do not blow directly with your mouth), and then wipe it with a fiber wiping cloth dipped in alcohol.

Embedding

When integrating EM23, you can refer to the following physical dimension specifications of each component. The structural design should not be too tight to ensure that other components will not oppress the EM23 electronic device; Reserve sufficient space for placing flexible cables, and leave space for cables to return to normal.

Assembly reference parameters (unit: mm)

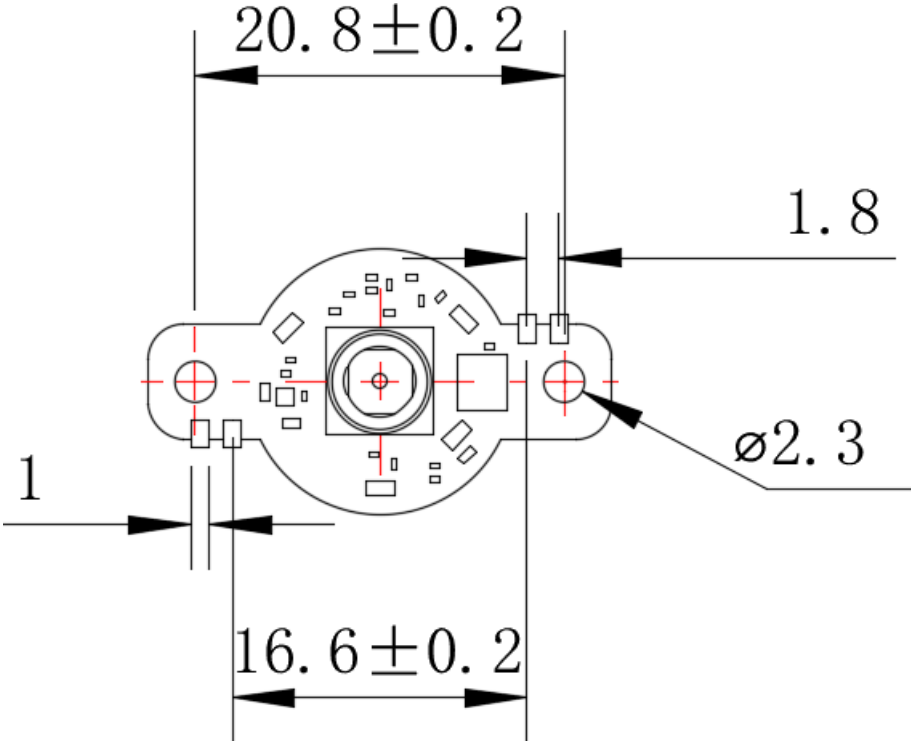

Figure2-1

Note: The unmarked tolerance is ± 0.15 mm ※

External design

※Note: Optical analysis shall be made for the housing design to ensure the best scanning or imaging performance.

The shell of the engine should be designed to ensure that no objects with strong luminous intensity (including but not limited to self-luminous light sources and bright spots generated by refraction/reflection) are placed within the engine field of view, so as to prevent the decoding performance from being affected by excessive local brightness in the captured image.

Consider using a baffle or a black matte material inside the shell.

Optical correlation

EM23 itself has no lighting system. If customers design their own lighting system, they should pay attention to the following contents.

Window positioning

Position the window so that the illumination light reflected from the window does not enter the engine. Improper window positioning will significantly reduce performance. Therefore, if the designed shell does not match the recommended window position and angle, please contact TouchThink to discuss the positioning requirements.

There are two options for window positioning:

Parallel windows-This is the preferred method for imaging engines.

Inclined window-used for laser or imaging engine.

※Note: For bar code reading, please use parallel or inclined windows. Dust, pollutants and scratches on the window may cause obvious defects in the image and even affect the decoding performance.

The window refers to the transparent medium installed in front of the EM23 engine, which is used to isolate the interior and exterior of the product, and reserve the vision for EM23 to read the barcode. The window should be placed so that the illumination beam can be emitted as much as possible and the reflection can not enter the engine. If the illumination beam reflects into the engine, it will reduce the reading performance of the engine.

The window should be installed as close as possible to the front of the EM23 engine and parallel to the front plane of the EM23. The distance is obtained by measuring the distance between the front plane of the EM23 and the farthest plane of the window. In order to get good reading performance, it is necessary to avoid the illumination light from reflecting into the engine through the window, so at the same time, the thickness of the window material should be reduced as much as possible. As shown in Figure 2-2 below, the vertical distance between the far end face of the window and the front end face of EM23 is not more than $a+d$ mm, and the vertical distance between the near end face of the window and the front end face of EM23 is not more than a mm ($a=0.1\text{mm}$, $d=2\text{mm}$). As the EM23 adopts a super-large lighting angle, it is suggested to add foam between the EM23 and the transparent screen to prevent the reflected light from entering the engine.

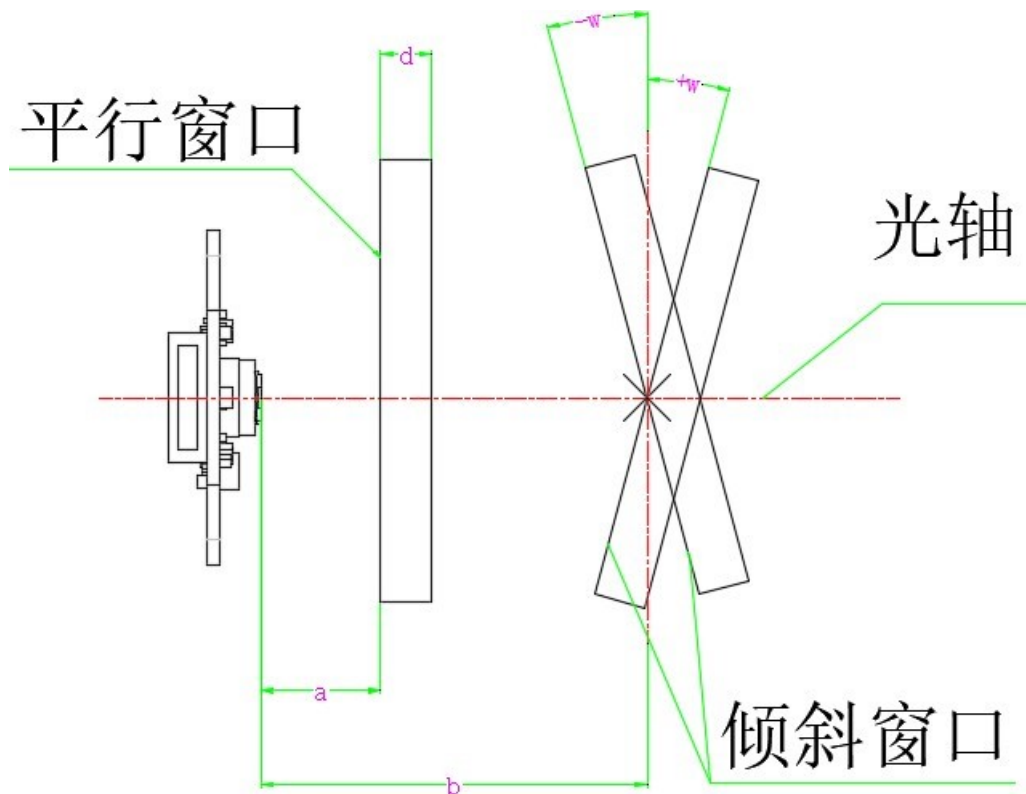

Please check the Chinese translation in the picture here: the left is Parallel window-ray axis-Inclined window

Figure2-2

Table 2-2:

Minimum angle of inclined window	Distance from front surface of engine (b)		
	The unit is millimeter.		
	10mm	15mm	20mm
Minimum window positive tilt (+w)	35°	30°	28°
Minimum window negative tilt (-w)			

If the window needs to be tilted, the distance is the same as that for parallel installation, and the center of the window and the center of the optical path should be consistent. The tilt angle should ensure that the light reflected by the glass cannot enter the lens.

Window material and color

The material and color of the window should be selected to ensure the transmittance of visible light as high as possible, while ensuring the ambiguity as low as possible and the uniform refractive index. Many seemingly transparent window materials have reduced performance due to their own stress and deformation, so they can only use cast plastic or optical glass (whether anti-reflective coating is used or not depends on the situation). The material and color of the window should make the transmittance of visible light greater than 92% and the ambiguity less than 1%. If it is necessary to add a transparent screen, it is recommended to coat the transparent screen with AR film. Table 2-3 summarizes the suggested window properties.

Table 2-3:

nature	desc ribe
thickness	General value 0.5-2.0mm
Transmission band	The transmission wavelength is 400-780nm.
clear aperture	Extend the effective area outward by 1.0 mm.
surface quality	60-20 scratch/dig

Pay special attention to the above-mentioned transmission band requirements when using plastic materials. Because surface scratches can cause image artifacts, it is not recommended to use plastic materials for inclined windows. In sports mode, colored windows will reduce the sensitivity of the engine to moving targets and are not recommended. And whether anti-reflection coating is used in the window material depends on the specific material and application. The following are descriptions of two commonly used window materials: PMMA and chemically toughened glass.

PMMA

PMMA has the advantages of transparency, strong impact resistance and low cost comparable to glass, but it is brittle and easy to crack, and its surface hardness is low, so it is easy to be scratched and lose its luster. Therefore, it is suggested to plate a hardened scratch-resistant film. When the window is made of PMMA, the recommended window thickness is 0.5-2mm, and the light transmittance of the substrate is more than 90%.

chemically strength tempered glass

Glass is a hard material with good scratch resistance and wear resistance. However, glass without annealing is brittle. The flexibility of glass can be improved by tempering treatment. Glass can't be welded by ultrasonic wave, and it is difficult to be cut into strange shapes. When the window is made of tempered glass, the recommended window thickness is 0.5-2mm, and the light transmittance of the substrate is greater than 91%.

Window scratch prevention and coating

Coating requirements

AR coating (anti-reflection film or anti-reflection film) on the window can effectively control stray light or achieve the maximum working range, and is applied to the inside and outside of the window to reduce light reflection. The average reflectivity can be less than 0.5% and the coverage band is 400-780nm by plating multi-layer AR film on the window.

Anti-scratch requirements

Scratch-resistant coating requires the hardness of the film to be more than 5H(2B pencil test), which can effectively improve the scratch resistance and wear resistance of the plastic or glass surface. If AR (anti-reflection film) coating is used, the specifications in table 2-4 apply. Scratch-resistant coating is not necessary. The window is designed as a groove to reduce scratching.

Table 2-4:

specifications	describe
material	Both toughened glass and plastic windows can be coated with AR film. Glass with anti-reflective coating is more durable because its glass structure has better adhesion. In addition, coating on glass material is more cost-effective than plastic material.
Specification for AR coating	Single-sided AR coating: the minimum transmittance in the spectral range of 400-780nm is 93%; Double-sided AR coating: The minimum transmittance in the spectral range of 400-780nm is ninety-seven percent. For parallel windows, please refer to Figure 2-2.

※Note: Scratches on the window will greatly reduce the reading performance of EM23. It is suggested that the window be designed as a groove or wear-resistant coating be used.

Window size

The basic requirement of window size design is to ensure that the field of view is not blocked. For the size design of the window, please refer to the following optical area diagrams. Optical area of lens and lens.

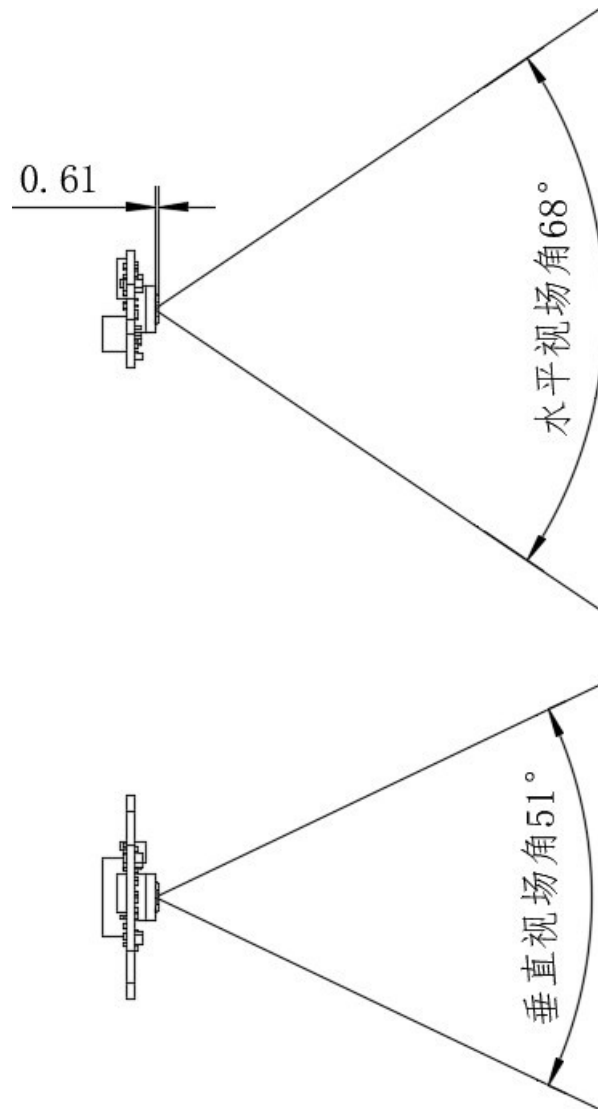

Please check the Chinese translation in the picture here: The horizontal viewing angle is 68 degrees./The vertical viewing angle is 51 degrees.

Figure 2-3

ambient light

EM23 is positioned as a screen reading engine, and the ambient light is too bright and directly enters the lens, which may affect the lens performance.

Human eye safety

EM23 does not use laser light source, but only uses light emitting diode (LED) as indicator, which meets the requirements of photobiological safety. The wavelength range of light waves generated by these LEDs is safe under normal use methods. The LED used in EM23 has a high luminous intensity, so it should be avoided to look directly at the LED or shoot the light beam at human eyes during use.

Interface definition

The physical interface of EM23 is an 8-PIN DuPont socket.

- 8-PIN FPC socket interface includes two communication forms: TTL-232 communication form and USB communication form.

Figure 3-1 indicates the positions of 8-PIN DuPont sockets on the EM23 decoding board, from right to left, in order of PIN1 ~ PIN 8.

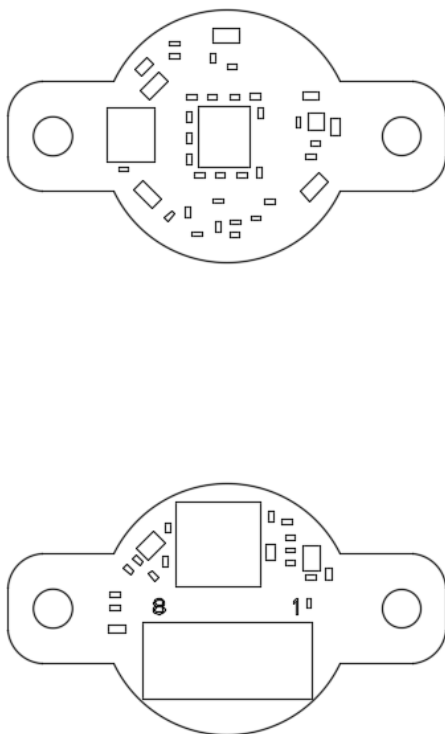

Figure3-1

Definition and description of 8-PIN DuPont socket

The specific signal of 8-PIN DuPont is defined as follows, as shown in Table 3-1:

Pin number	Signal name	I/O type	Default state	functional description	remarks
one	3.3V	P	-	Power input	
2	GND	-		GND	
three	NTRIG	I	PU	External trigger input signal, low active	※1
four	BUZZ	O	PD	Buzzer output signal, high effective.	※2
five	USB_D+	A		USB_D+ signal	
six	USB_D-	A		USB_D- signal	
seven	TTL_TXD	O		TTL_232 serial port signal transmission	
eight	TTL_RXD	I		TTL_232 serial port signal reception	

※The signal of Pin 3 nTRIG of 8 Pin interface of 1em23 module is not directly taken from MCU pin, so the effective high and low level of pin is different from other input and output ports. When designing the external control module, users must refer to the IO level in Table 4-3 of Electrical Characteristics in Chapter 4.

There are two ways to trigger external input, level trigger and pulse trigger.

Level trigger: the trigger signal can be input through external keys. For the external drive circuit, please refer to the section of trigger function reference circuit in Chapter 5. Pulse trigger: the effective pulse width is not less than 50ms. After the pulse signal is provided, it will last for an effective decoding time, during which it will stop immediately if the code word is decoded, and until the time ends if the code word is not decoded within the duration. The time length can be set. For details, please refer to the corresponding chapter of EM23 User Manual for setting.

When this pin is not used, it can be suspended.

※2 There are two output states of buzzer signal:

There are two output states of buzzer signal: when the buzzer is powered on for about 215ms, it outputs PWM signal for startup prompt, including four frequencies, 2.09KHz, 2.63KHz, 3.13KHz and 4.26KHz, and the duration is about 400 ms.. When the decoding is successful, PWM can output signals with three different frequencies, the frequencies are 2.71KHz,

3.94KHz and 4.80KHz, the default output PWM frequency of the system is 2.71KHz, and the duration is about 80 ms.. Please refer to the relevant chapters of EM23 User Manual for the method of turning on or off the power-on prompt tone and setting the output frequency of the successful decoding prompt. In the process of buzzer selection, the resonant frequency of buzzer should be as close as possible to the output frequency of PWM to ensure the best effect.

For external driving circuit, please refer to Chapter 5 Buzzer Reference Circuit. When this pin is not used, it can be suspended.

Connector specifications and dimensions

The external interface on EM23 is an 8-PIN DuPont connector.

8-PIN DuPont connector

8 PIN DuPont socket adopts DuPont socket of Pintuopin Company, model 1.0T-8AWB.

Precautions:

1. Minimize the number of cable disassembly and assembly.

Power requirement

Before supplying power to EM23, ensure that EM23 is connected correctly. If the EM23 is plugged or unplugged with electricity (hot plug), the electronic components of the EM23 will be damaged. Please ensure that the power supply is cut off when plugging and unplugging cables.

Bad power connection, short interval power off and on operation, or excessive voltage drop pulse may cause EM23 to be unable to work stably and normally, so it is necessary to keep the power input stable.

When designing, users should ensure that the input power of EM23 is fully decoupled. It is suggested that a 22uF and a 100nF X5R or X7R ceramic capacitor be placed at the power input pin of the socket connected to EM23 on the user board, and the capacitor mounted on the external input power supply VDD should be controlled within 50uF. ※

※After the EM23 is controlled to be powered off, before the power-on operation, it is necessary to ensure that the input power supply falls below 0.5V before the power-on operation, otherwise the equipment may work abnormally.

Ripple noise

In order to run reliably, low noise power supply is needed. Pay due attention to power quality and testing to ensure that EM23 can get the best performance. Therefore, the input ripple of EM23 module power supply must not exceed 100mV.

Dc characteristics

operating voltage

(T=25°C), Table 4-1:

sign	explain	minimum value	typical value	maximum	unit
VDD	System input voltage	3.14	3.3	3.47	V

operational current

(T=25°C), Table 4-2:

model	condition	PEAK	RMS	unit
operational current	VDD=3.3V	160	100	mA
Standby current		-	11.8	mA

I/O level

Vdd = 3.3v, GND = 0v, T = 25 C, as shown in Table 4-3:

sign	explain	cond ition	minimum value	maximum	unit
VIL	Input low level	In addition to the nTRIG pin.	-	0.8	V
VIH	Input high level	In addition to the nTRIG pin.	2	-	V
VIL(1)	Input low level	NTRIG pin only	-	2.2 (VDD-1.1)	V
VIH(1)	Input high level	NTRIG pin only	2.9 (VDD-0.4)	-	V
VOL	Output low level	Iol= 4mA~16mA		0.4	V
VOH	Output high level	Ioh= 4mA~16mA	2.4		V

1. The threshold of high and low levels of nTRIG is related to the external power supply voltage VDD, and the input low level VIL of nTRIG should not be higher than VDD-1.1, and the input high level VIH of nTRIG.

Should not be lower than VDD-0.4.

Power sequence

Power on sequence

Timing diagram of power-on operation:

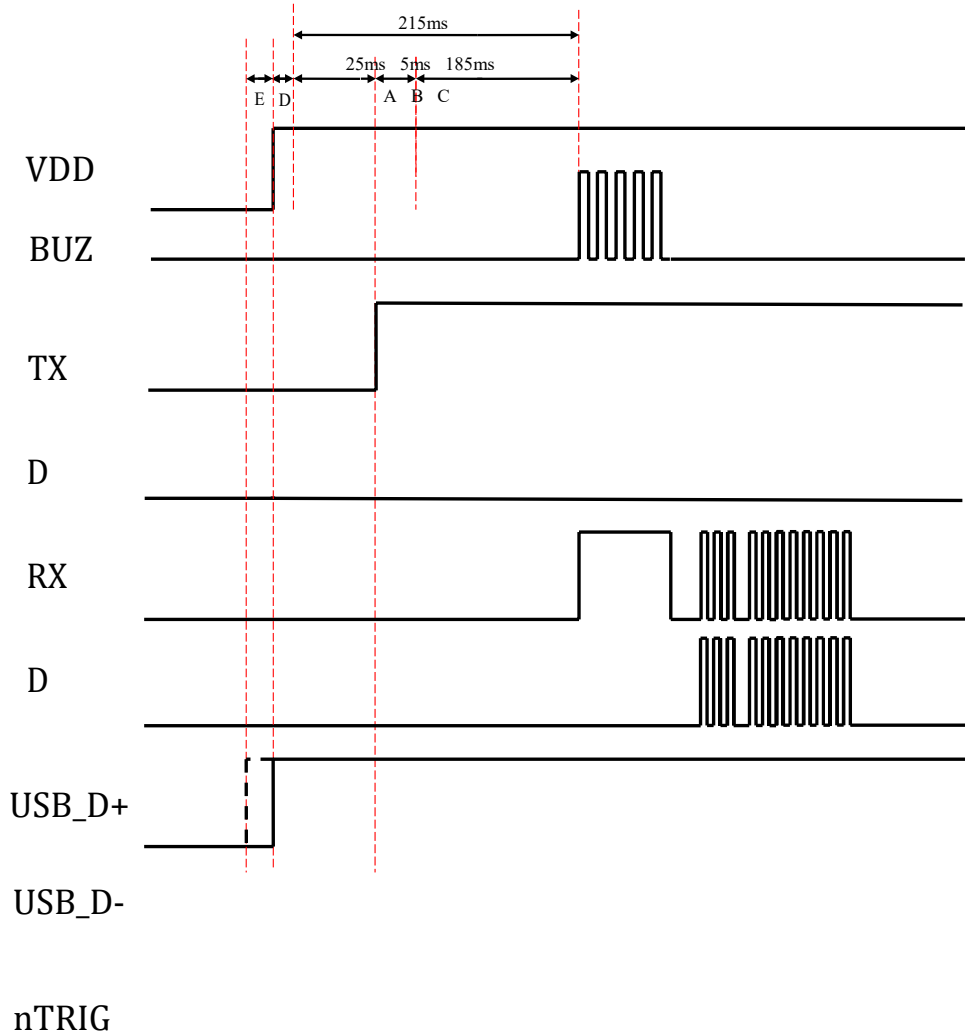

Figure 4-1 Total Power-on Timing

Note: 1. In the above figure, A is the Boot completion time, B is the kernel startup completion time, and C is the decoding chip initialization completion time. The total boot completion time is about

215ms.

2. In the above figure, d is the Reset time (about 300us). If no extra operation is performed on the reset signal during actual power-on, the startup time of the system can be counted from VCC_3V3 to 3.3V.

3. When powering down, please ensure that the data of all communication interfaces have been transmitted before powering down, so as to avoid transmission errors.

4. EM23 module has its own 100K pull-up on the nTRIG signal. During the period from power-on of the module to the

completion of BOOT startup, users are not allowed to force the nTRIG signal to be pulled down. If nTRIG is set high before power-on, it should also meet the requirements of E period in Figure 4-1 ($E=0\sim 1\text{ms}$), otherwise there will be startup abnormality. The levels of other signals are kept low during the power-on process to prevent the module from working abnormally due to current back-injection.

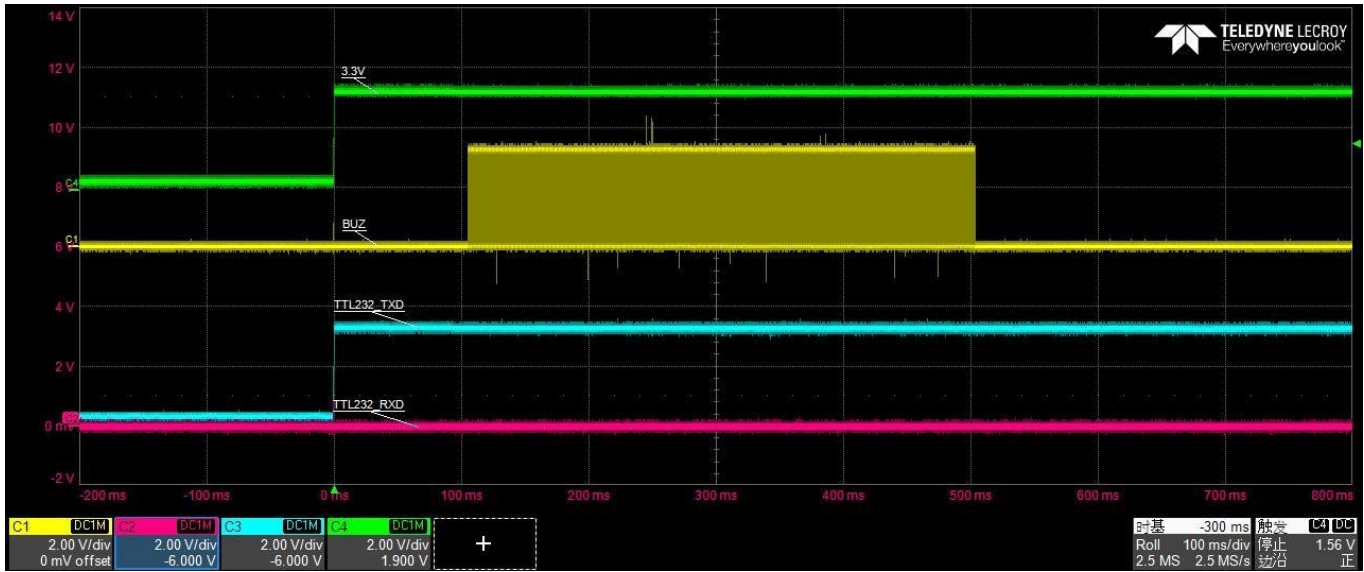

Figure 4-2 Serial Port Power-on Timing

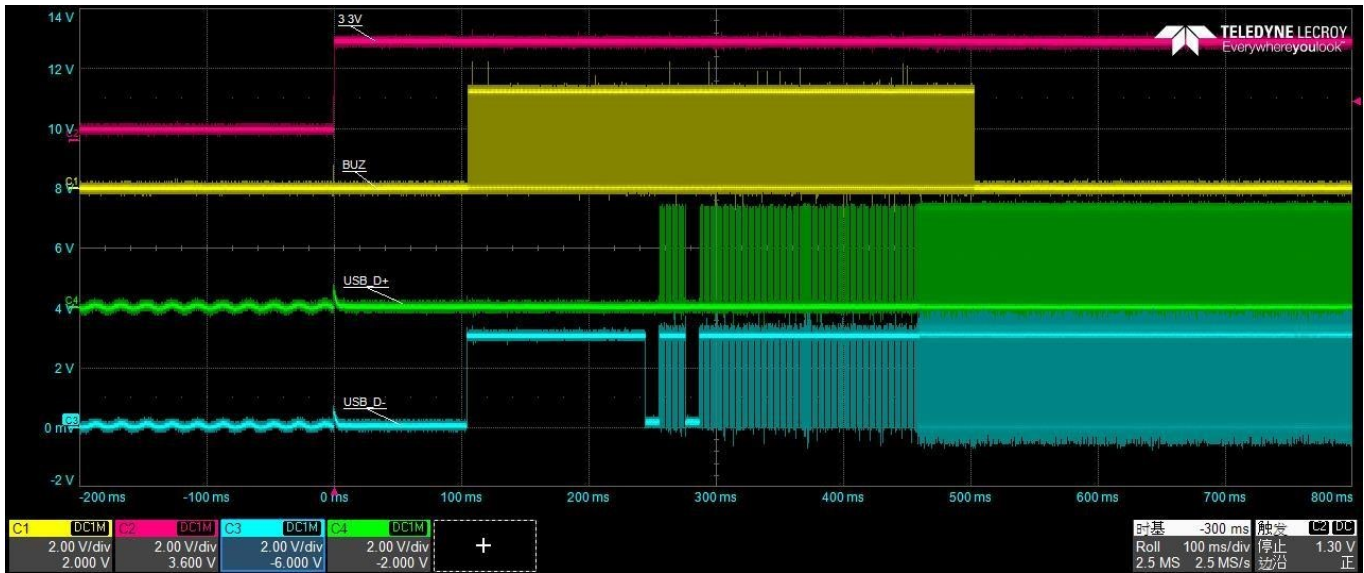

Figure 4-3 USB power-on sequence

Power-down sequence

Power-down timing diagram:

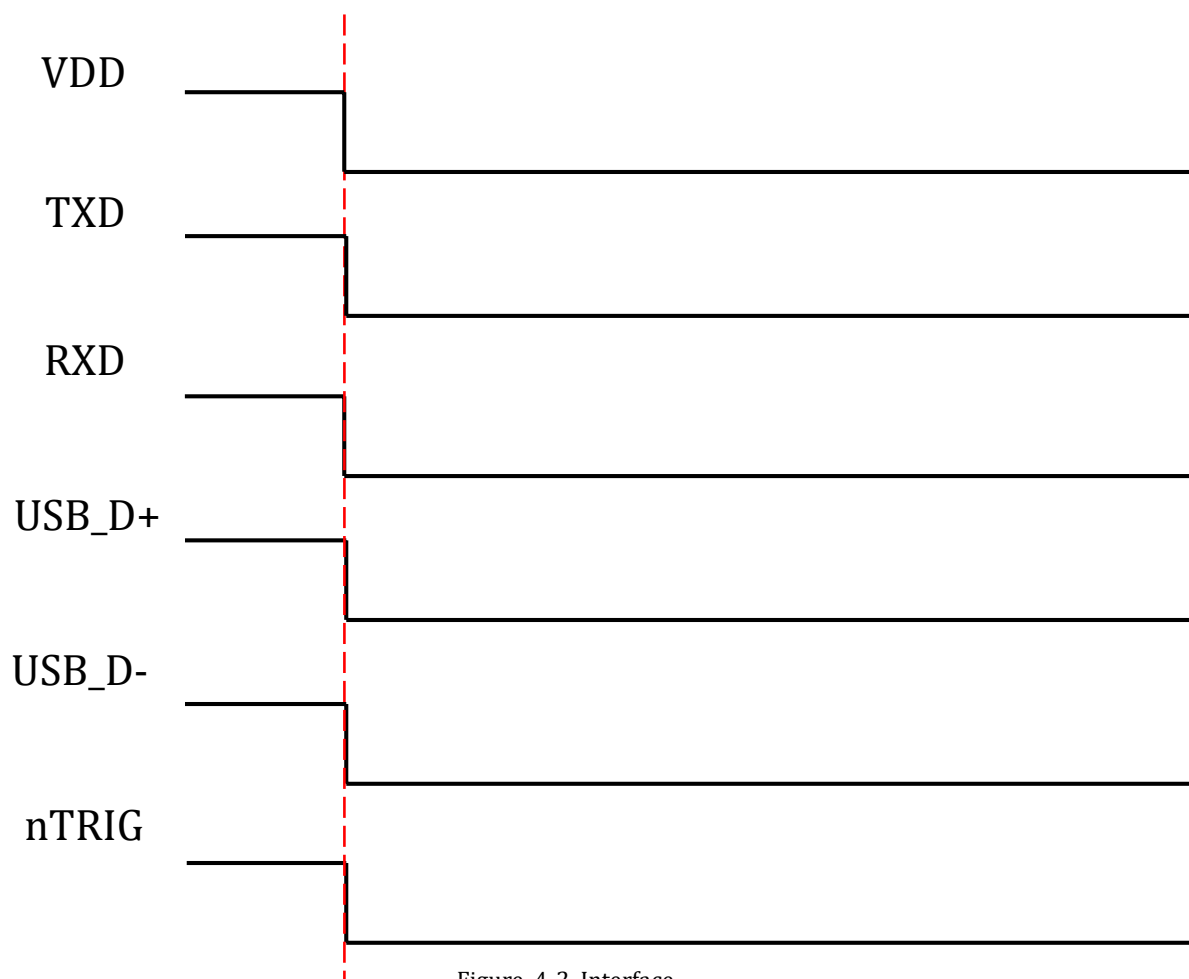

Figure 4-2 Interface
Signal Power-on Timing

Note: When the module is powered down, it is necessary to cut off the input power of the module, and also ensure that the signals such as TXD, RXD, USB_D+, USB_D- and nTRIG of the EM23 interface are all at low level during the power failure, otherwise there will be current back-injection, which may lead to abnormal power-up of the module.

External circuit reference design

Buzzer reference circuit

Figure 5-1 provides the external circuit reference design of the buzzer, which is used to realize the buzzer sound function. The left part of the picture is the control signal BUZ on the EM23 decoding board, and only the reference design on the right part is needed in the application. For the output frequency of PWM and the selection suggestion of buzzer, please refer to Note 1 of Table 3-1 in Chapter 3.

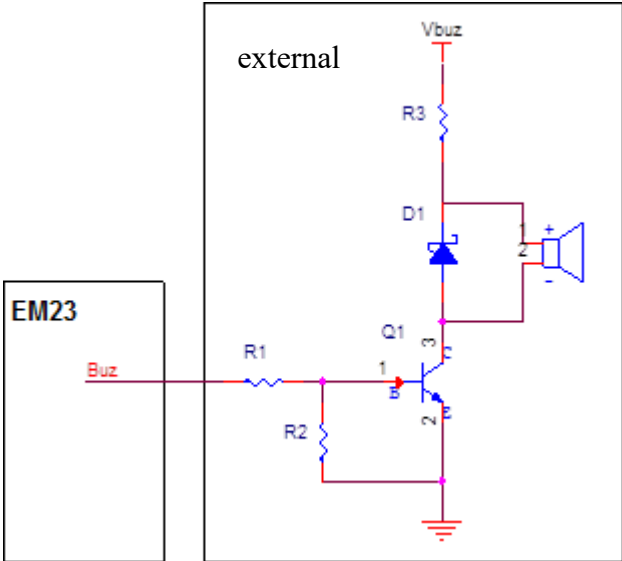

Figure 5-1

Trigger function reference circuit

Fig. 5-2 provides a circuit reference design of the trigger function, which is used to provide an effective trigger signal level for EM23 to generate a reading action. The left part of the figure is the driving signal nTrig on the EM23 board, and only the reference design on the right part is needed in the application. nTRIG signal comes from Pin 3 on 8-PIN DuPont.

The host can adjust the external circuit and its functions according to the specific application requirements, and the matching with the circuit of the decoding board itself should be considered in the design. The R1 resistance is recommended to be 10K-100K. R2 resistance is recommended to be 33Ω. C1 is used to eliminate the jitter of mechanical keys. Generally, ceramic capacitors of 1nF-10nF are selected, and the appropriate capacitance value is selected according to the test situation. When ESD protection is required, an ESD protection device can be added to the external circuit as shown in the figure below.

When the external IO port is used as the trigger output, it should be noted that its output level must meet the level requirements provided in Table 4-3 in Chapter 4, Electrical Characteristics. It is suggested to use default Floating or default pull-up IO port as trigger pin in design. If the default pull-down IO port can only be used as the trigger pin, it is recommended to refer to the power-on timing requirements in Figure 4-1, and ensure that the pin state can still meet the high level range required in Table 4-3 when it is not triggered.

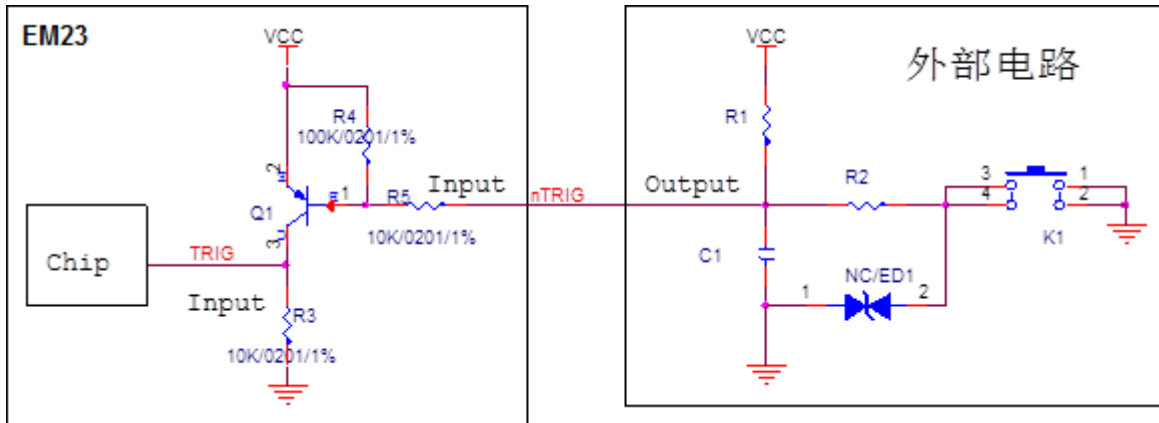

Figure 5-2

Please check the Chinese translation in the picture here: External circuit

EM23 has hardware auxiliary tools and software auxiliary tools to quickly support application development. It can not only meet the needs of rapid evaluation and development, but also meet the rapid function configuration and deployment for special applications.

EasySet

Newland provides tools and software such as EasySet, which can run under Windows system, connect with EM23 through EVK and other tools, and can change and set various

