

R15IM3S-GSC3(HB)

15" ARM A53 G-WIN GS-Series Full IP65 PCAP Panel PC



KEY FEATURES

- 15" 1024 x 768 with PCAP touchscreen
- ARM A53 Quad Core 2.0GHz
- Fanless cooling system and Ultralow power consumption
- Onboard 32GB eMMC
- Onboard LPDDR4 4GB
- Full IP65
- 1 x LAN, 1 x RS232, 1 x USB, 1 x Micro USB, 1 x Micro SD
- Support Android or Linux operating system



SPECIFICATIONS

Display			
Touch / Glass	Projected Capacitive Multi Touch Screen Protection Glass (Optional) Anti-glare Coating (Optional)	Resolution	1024x768
Size	15 inches	Contrast Ratio	2000:1
Panel Brightness	300 nits 1000 nits(Optional)	View Angles	88,88,88,88
Active Area	304.1x228.1 mm		
System Specification			
Processor	ARM A53 Quad Core 2.0GHz	Memory	4GB LPDDR4
Storage	32GB eMMC	Operating System	Android 11 (Upgradeable to Android 13) Linux Yocto 5.10.104 with QT 5.15 (Optional) Linux Ubuntu (in 2023) (Optional)
Environment			
Operating Humidity	10% to 95% RH	Operating Temperature	-15°C~55°C
Storage Temperature	-30°C~60°C	Shock	40g for 11ms
Vibration	1.48/1.90/2.24 g rms for XYZ/ 5-500Hz	IP rating	Full IP65
Certification			
Certification	CE, FCC		
IO Ports			
USB Port	1 X USB 2.0 (M12 type) 1 X Micro USB	Serial Port	1 x RS232 (M12 type)(Optional 422/485)
SD Card Slot	1 x Micro SD card slot (Max to 32GB)	Audio	2 x Speaker
LAN	1 x LAN 10/100/1000 Mbps (M12 type)		
Mechanical			
Dimension	363.4 x 277.9 x 45.2 mm	Mounting	Panel Mount VESA Mount
Enclosure	Aluminum	Cooling System	Fanless Design
Power			
Power Rating	12V DC (M12 type)		

Accessory

Accessory	Quick Start Guide (Hardcopy) M12 Power Cable M12 Serial Interface Cable M12 USB/ LAN Cable I/O Protective Cap x 3
-----------	---

DIMENSIONS UNIT:MM

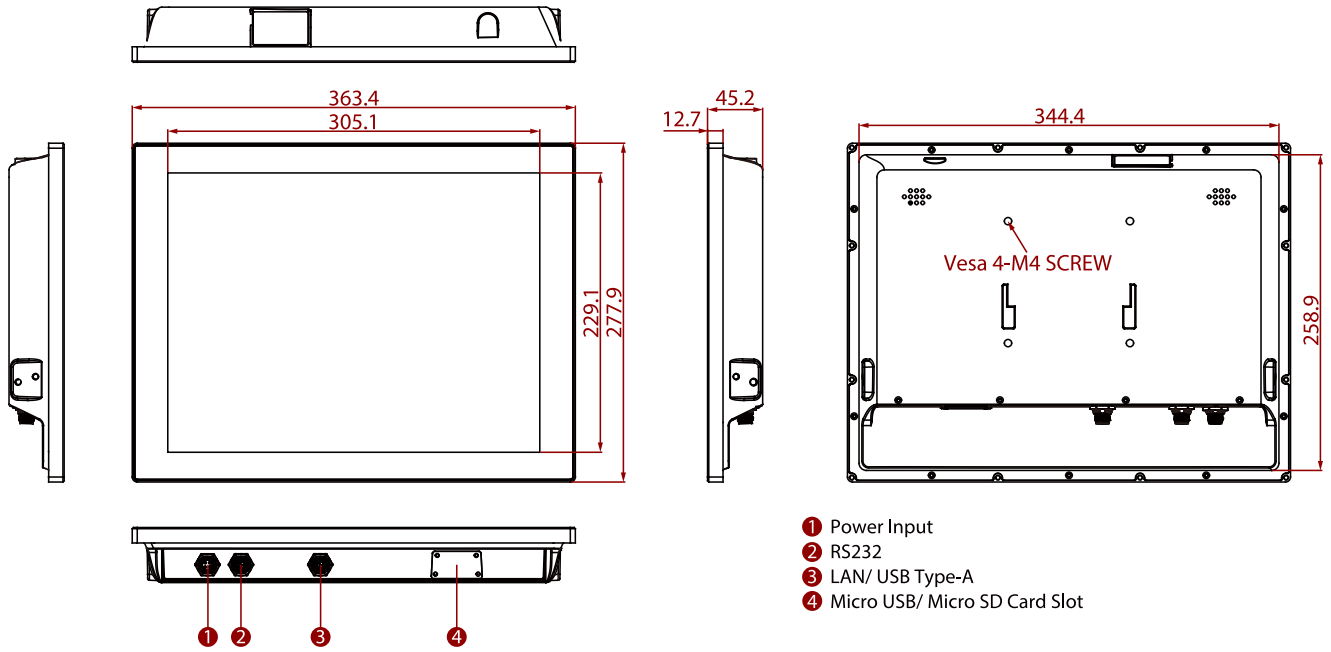

NOTE

1. This is a simplified drawing and some components are not marked in detail.
2. Please contact our sales representative if you need further product information.
3. All specifications are subject to change without prior notice.
4. The product shown in this datasheet is a standard model. For diagrams that contain customized or optional I/O, please contact the Winmate Sales Team for more information.